

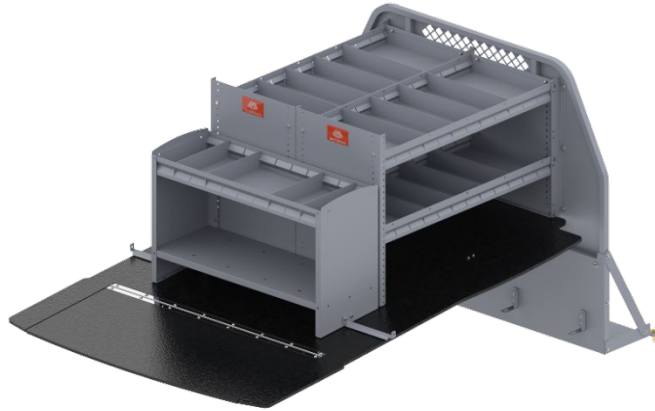

STANDARD WORK INSTRUCTIONS



NISSAN PATHFINDER



NISSAN ROGUE



NISSAN KICKS

TABLE OF CONTENTS

Standard Warnings.....	2
Part Identification / BOM.....	2
Recommended Tools.....	3
1. Assembly.....	3-14
1.1 Rear shelving module assembly (02U258KP) (Pathfinder, Rogue and Kicks)	
1.2 Side shelving module assembly Nissan Pathfinder (02U040KP)	
1.3 Side shelving module assembly Nissan Rogue (02U403KP)	
1.4 Side shelving module assembly Nissan Kicks (02U203KP)	
2. Installation Instruction.....	15-20
2.1 Shelving module installation Nissan Pathfinder	
2.2 Shelving module installation Nissan Rogue	
2.3 Shelving module installation Nissan Kicks	

STANDARD WARNING

- Read work instructions in entirety before starting.
- Check that you are properly clear of the gas tank and wires before drilling.
- Contact Masterack if questions arise, or the document needs to be updated.
- Follow all listed OEM system functionality checks after installation.

PART IDENTIFICATION / BOM

DESCRIPTION	PATHFINDER	QTY	ROGUE	QTY	KICKS	QTY
REAR SHELVING MODULE PARTS						
UPR TPR BTM 22X12 – LH	02U044	1	02U044	1	02U044	1
UPR TPR BTM 22X12 – RH	02U054	1	02U054	1	02U054	1
PARTS TRAY 12X32	02U045	1	02U045	1	02U045	1
SHELF STEEL 20GA 12X32	02U046	1	02U046	1	02U046	1
PTS TRY DVDR 12- SET OF 4	021391	1	021391	1	021391	1
MOUNTING BRACKETS						
MTG BRKT FRT PRT NF2 SET OF 2	02U043KP	1	02U043KP	1	N/A	N/A
MNTG BRKT, KICKS, SET OF 2	N/A	N/A	N/A	N/A	02U248KP	1
KIT PACK MTG BRKT RR MDL NF2	02U047KP	1	N/A	N/A	N/A	N/A
SIDE SHELVING MODULE PARTS						
UPRIGHT SOLID 22 X 16	025885	1	025885	1	025885	2
UPR SOL 28X16	02S868	1	N/A	N/A	N/A	N/A
UPR SOL 24X16 R & L	N/A	N/A	02P254	1	N/A	N/A
PARTS TRAY 16X37	028407	2	028407	2	N/A	N/A
PARTS TRAY 16X25	N/A	N/A	N/A	N/A	028405	2
PTS TRAY DVDRS 16- SET OF 4	027547	2	027547	2	027547	2

HARDWARE'S FOR ALL SHELVING MODULES						
DESCRIPTION	PATHFINDER	QTY	ROGUE	QTY	KICKS	QTY
SCREW HHM 1/4-20X2.50	RM511429	1	RM511429	1	RM511429	1
SCREW HWH1/4-20X3/4-GR5-STL-ZI	RM511458	36	RM511458	36	RM511458	28
SCREW HWH1/4-20X1-1/4-GR5-ZI	RM511477	6	RM511477	6	RM511477	6
NUT PLUS 1/4-20	RM520113	6	RM520113	6	RM520113	6
NUT ESH 1/4-20	RM520312	36	RM520312	36	RM520312	28
WASHER FENDER 1/4	RM541033	4	RM541033	4	RM541033	4
COLR 3/4IDX1ODX3/8THK ZN	RM560143-1	8	RM560143-1	8	RM560143-1	8
SCREW HHC 1/4-20X1.75	RM511434	6	RM511434	6	N/A	N/A
WASHER FLAT 1/4	RM541013	6	RM541013	6	N/A	N/A

RECOMMENDED TOOLS

- Impact Driver
- Torque Wrench
- 3/8 Socket
- 7/16 Socket
- 7/16 Combination Wrench
- 3/8 Combination Wrench

ASSEMBLY

1.1 REAR SHELVING MODULE ASSEMBLY (02U258KP)

- Use SCREW HWHM 1/4-20X.75 and NUT ESH 1/4-20 for assembling parts.
- Attach SHELF METAL 12X32 and PARTS TRAY 12X32 between two uprights using top and bottom holes on the uprights LH and RH as shown below.

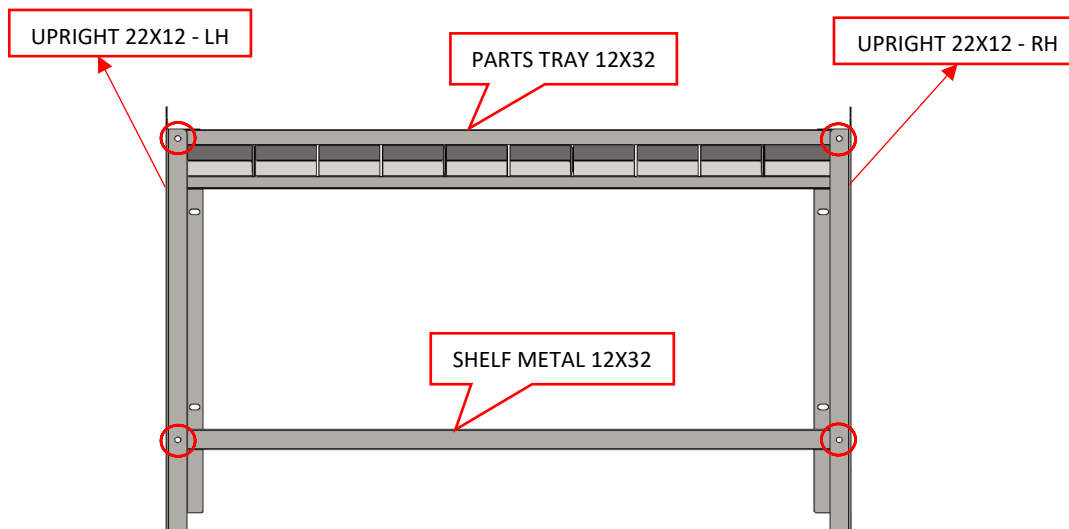

- Upright LH (02U044) & Upright RH (02U054)

Position the Upright on the hole with the shelf as mentioned in the below image

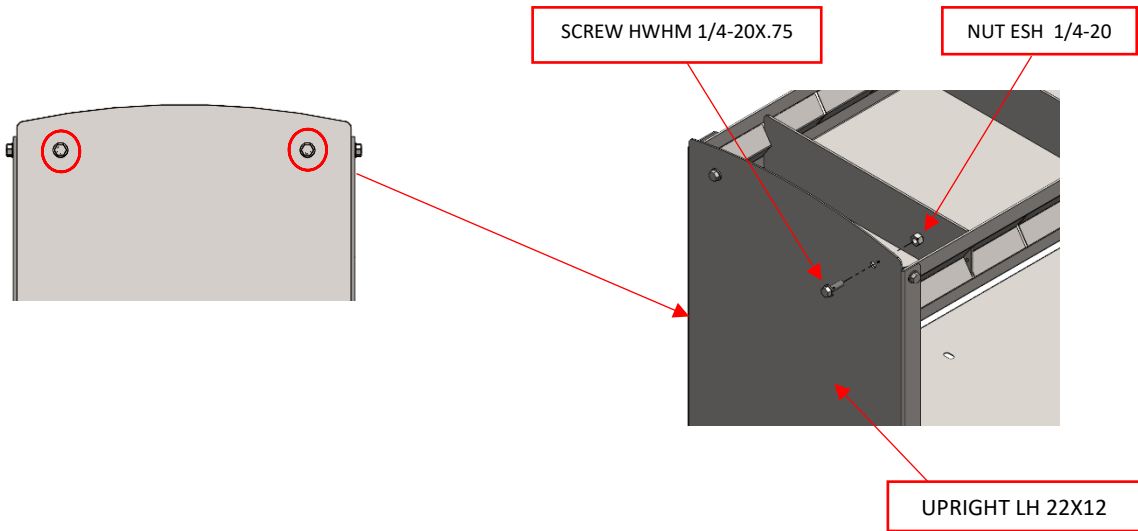

- Assemble SHELF METAL and PARTS TRAY 12X32 between the uprights at appropriate heights as shown below.

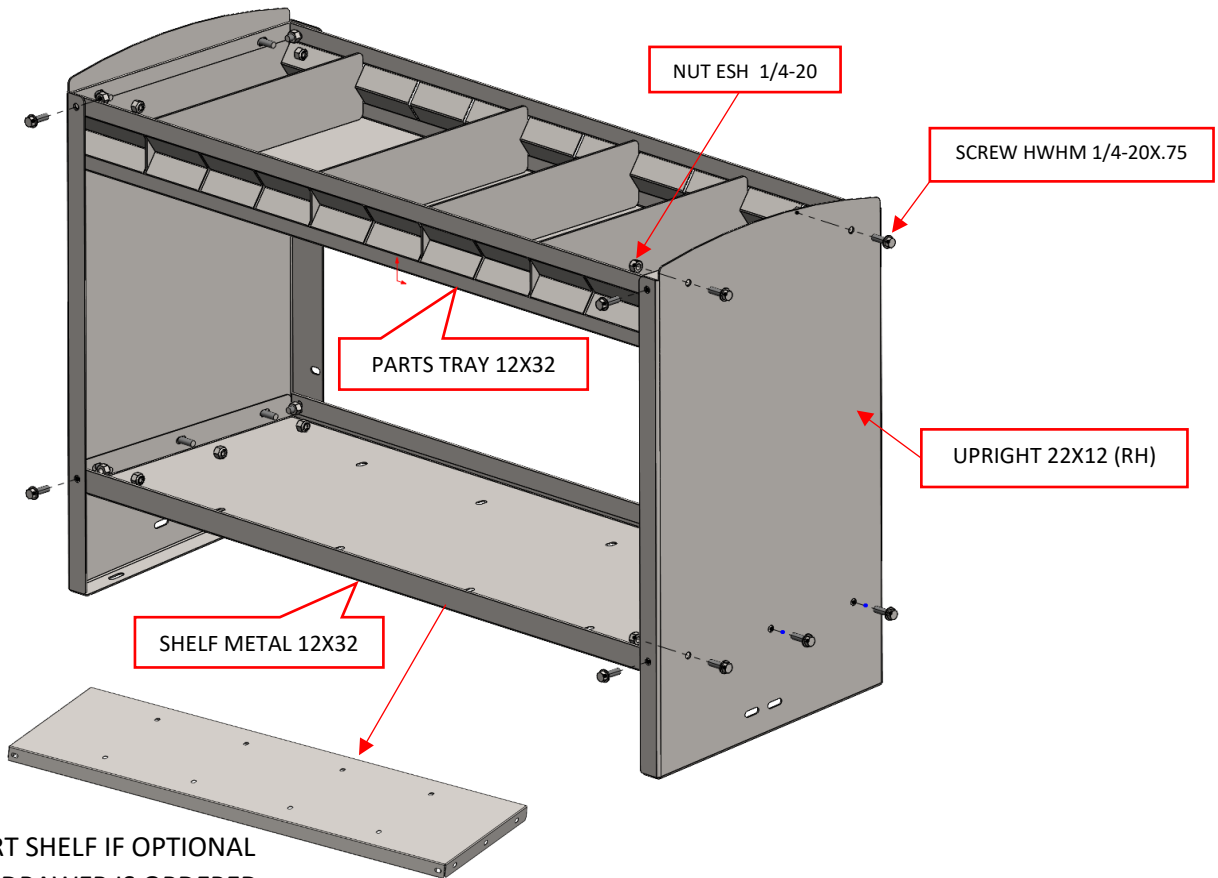

- Images show mounting position for 02U045 - PARTS TRAY and 02U046 – SHELF METAL between 02U044 and 02U054 uprights.

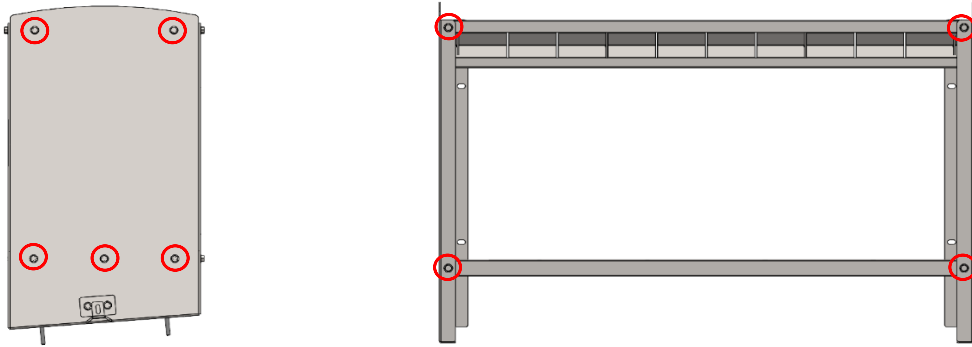

- Assemble four tray dividers using the slots provided in the shelf as per the requirements as shown below.

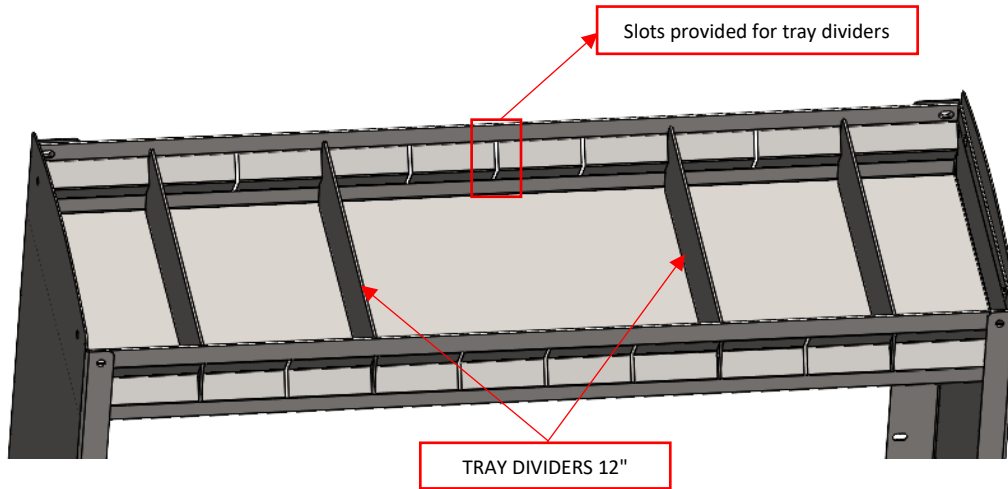

- 4 holes will be drilled on the floor (for LH and RH uprights) of the van using templates. The module will be positioned in the van and installed using (4) 1/4 lock washers, (4) 1/4 flat washers and (4) SCREW HWHM 1/4-20X3/4.

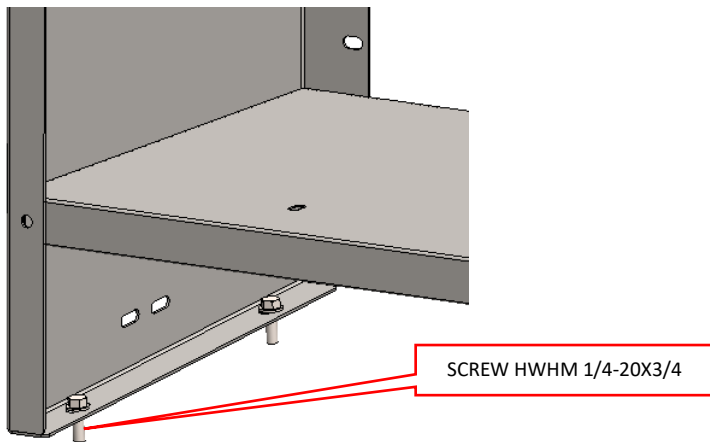

1.2 SIDE SHELVING MODULE ASSEMBLY (02U040KP) - PATHFINDER

- Use SCREW HWHM 1/4-20X.75 and NUT ESH 1/4-20 for assembling parts.
- Attach PARTS TRAY 16X37 between two uprights using holes.

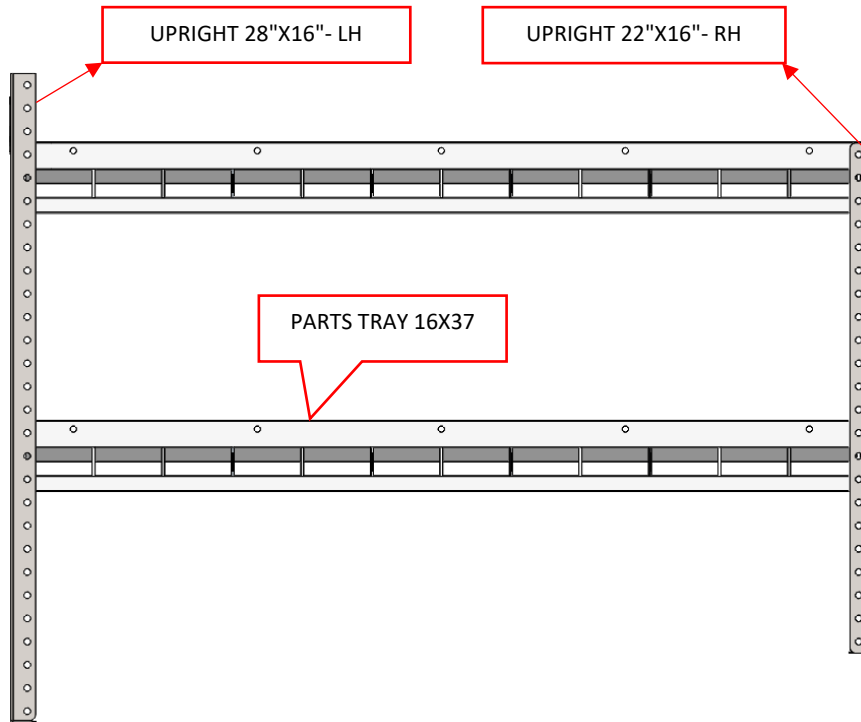

- Take UPRIGHT 28"X16"- LH (02S868)
- Use the 4th hole from the top on the upright 02S868 (LH) to mount the top shelf, as shown in the image below.

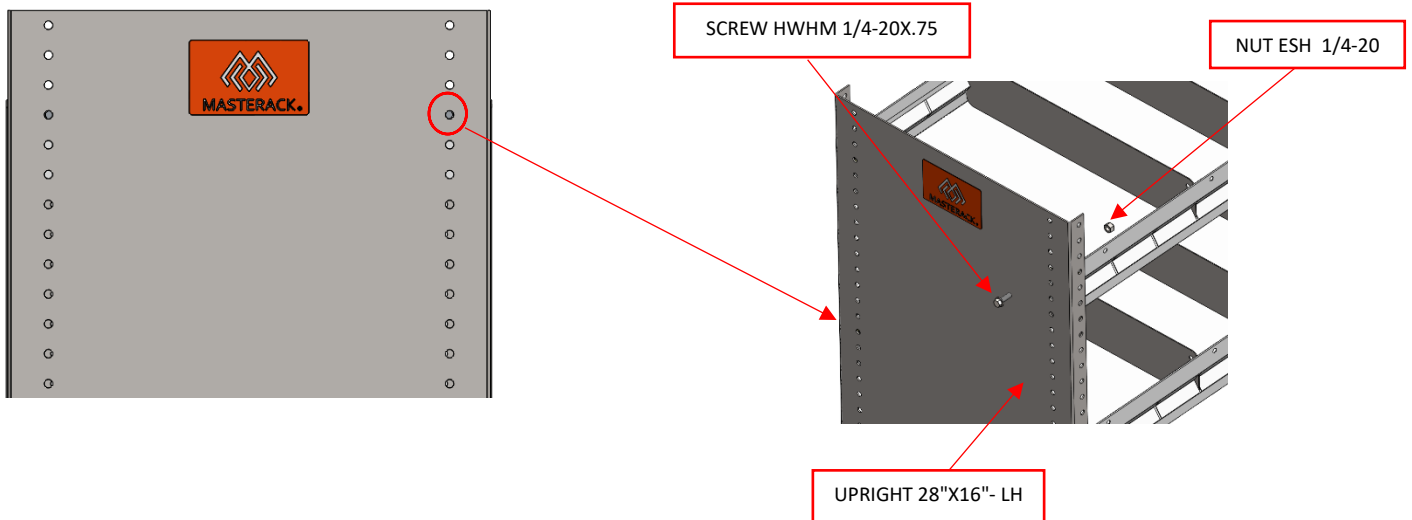

- Take UPRIGHT 22"X16"- RH (025885)
- Use the 1st hole from the top on the upright 025885 (RH) to mount the top shelf, as shown in the image below.

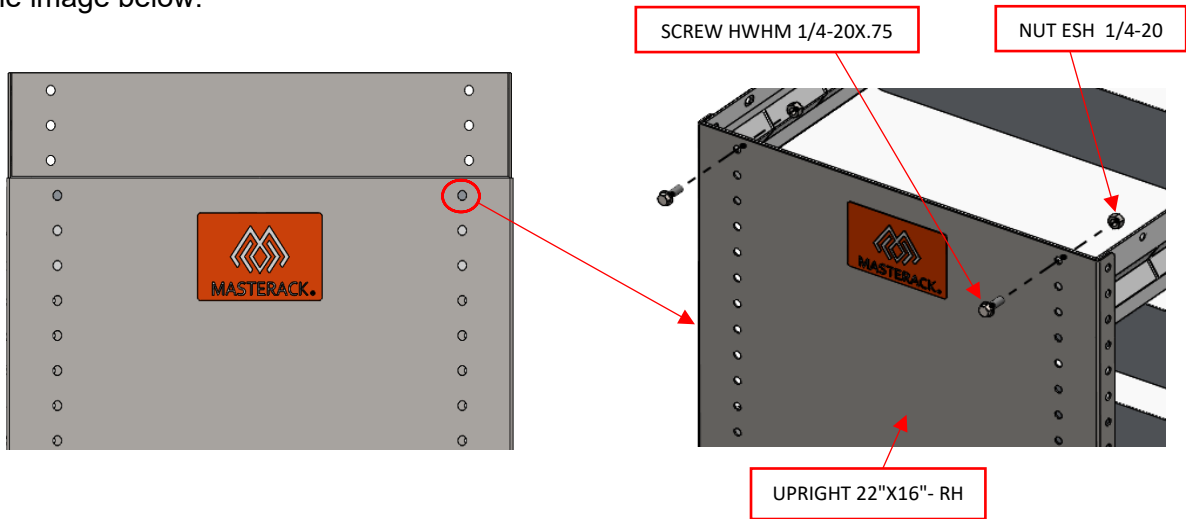

- Assemble two PARTS TRAY 16X37 between the uprights at appropriate heights as shown below.

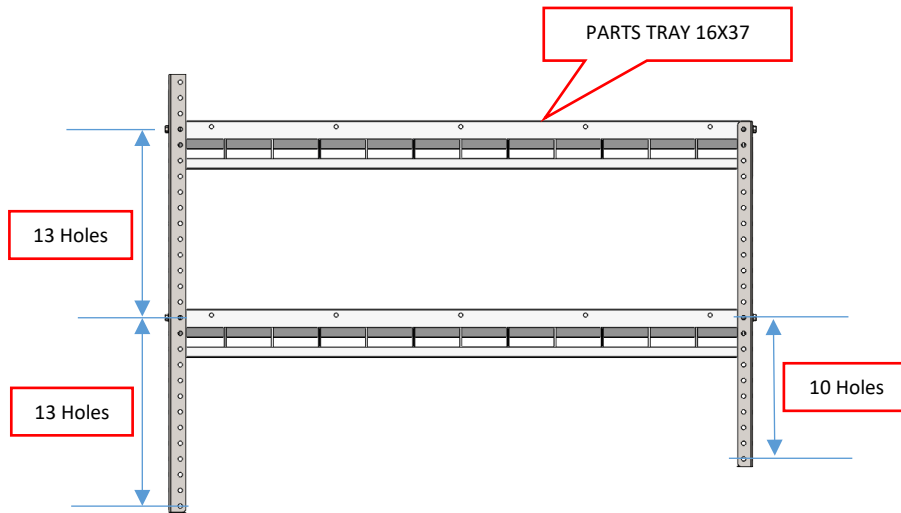

- Below images show mounting position for 028407 – PARTS TRAY between 02S868 and 025885 uprights

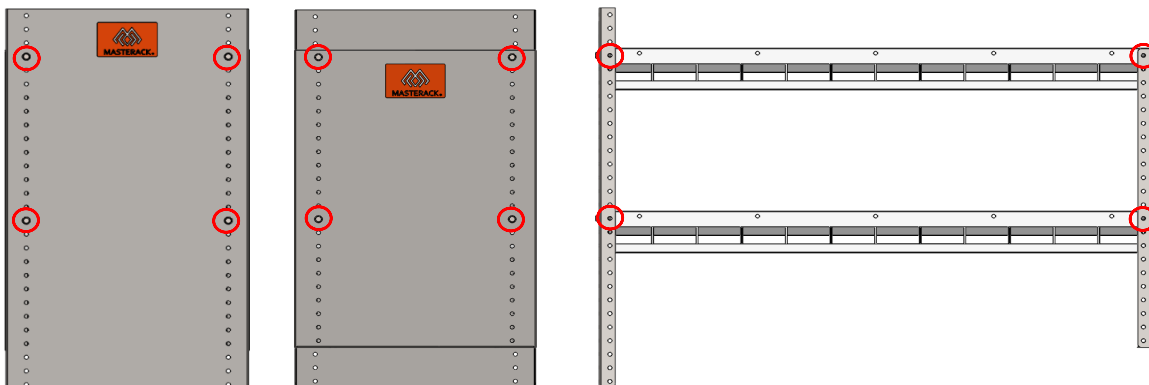

- Assemble tray dividers using the slots provided in the Top and bottom shelf as per the requirement as shown below.

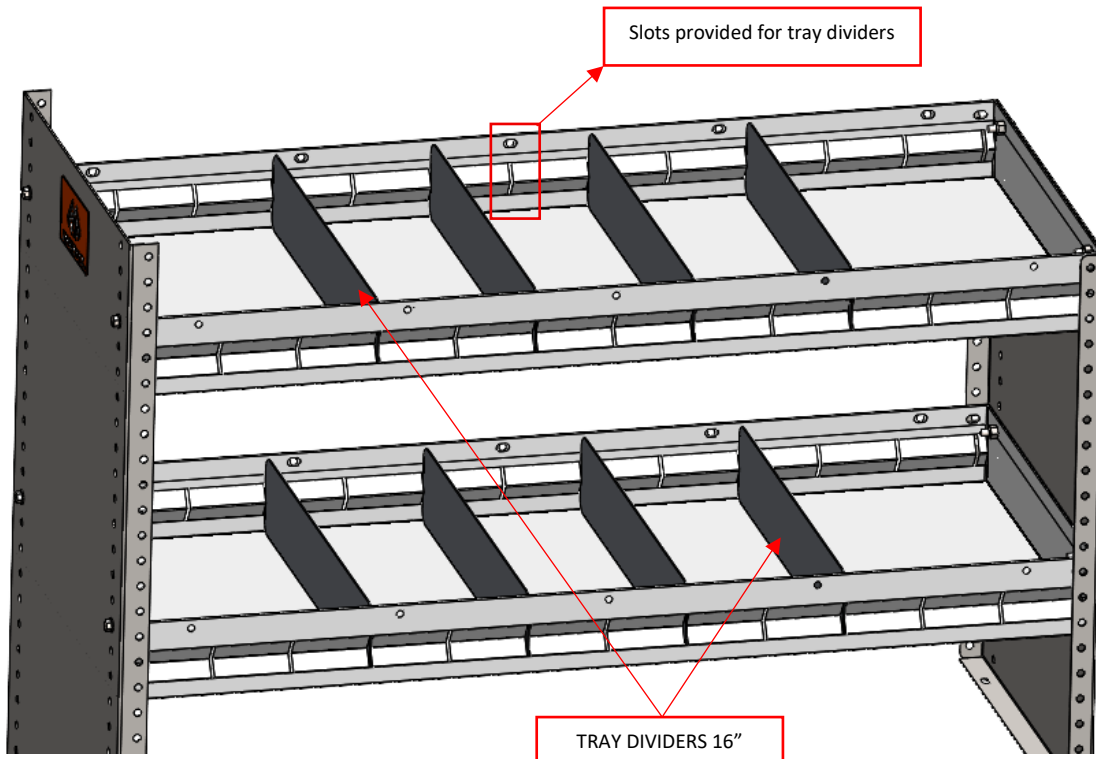

- 4 holes will be drilled on the floor (for LH and RH uprights) of the van using templates. The module will be positioned in the van and installed using (4) 1/4 lock washers, (4) 1/4 flat washers and (4) SCREW HWHM 1/4-20X3/4.

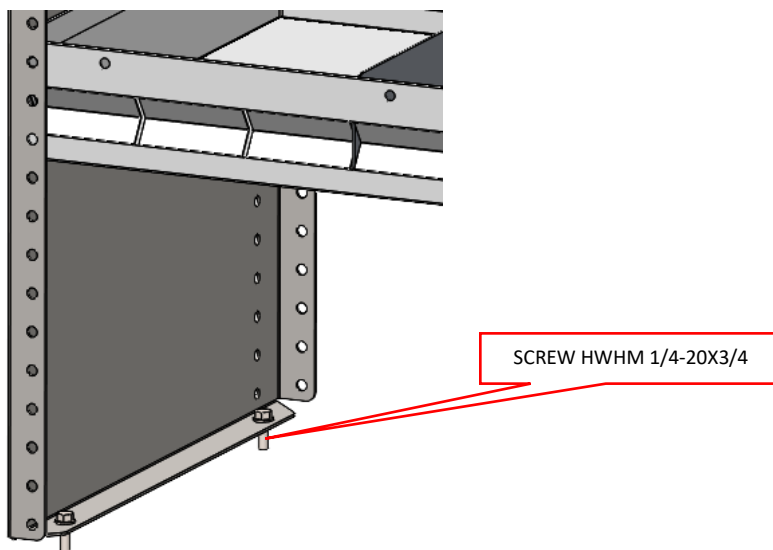

1.3 SIDE SHELVING MODULE ASSEMBLY (02U403KP) – ROGUE

- Use SCREW HWHM 1/4-20X.75 and NUT ESH 1/4-20 for assembling part.
- Attach TWO PARTS TRAY 16X37 between two up rights using holes.

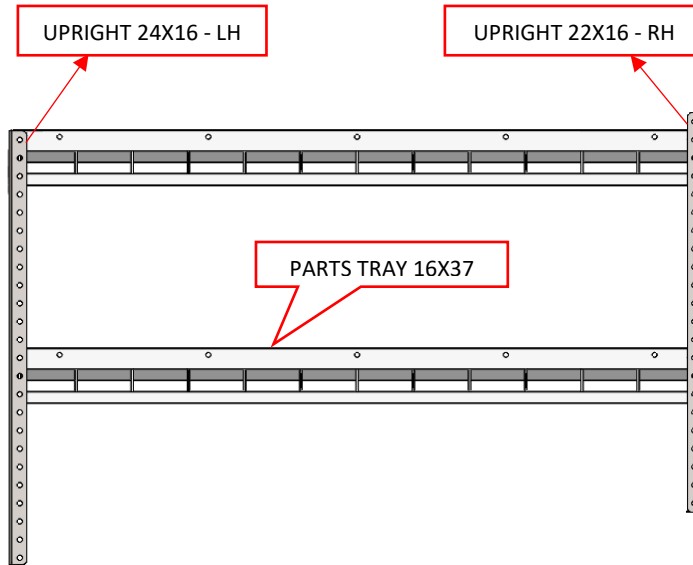

- Take UPRIGHT 24X16 – LH (02P254)
- Use the 1st hole from the top on the upright 02P254 Upright (LH) to mount the top shelf, as shown in the image below

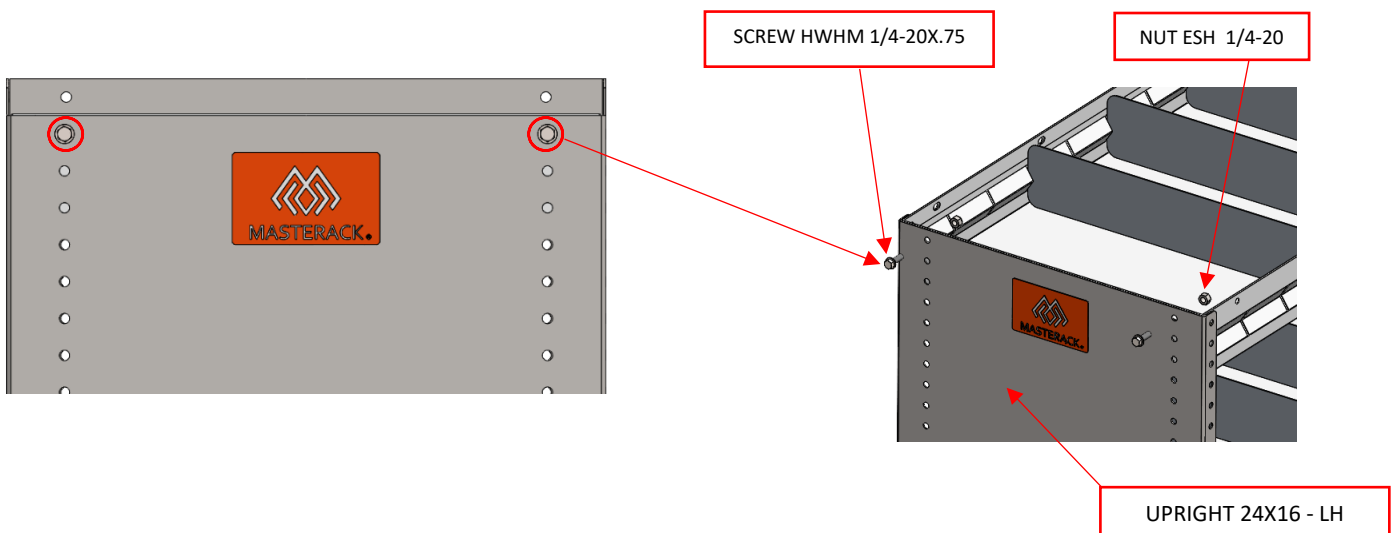

- Take UPRIGHT 22X16 – RH (025885)
- Use the 2nd hole from the top on the upright 025885 (RH) to mount the top shelf, as shown in the image below.

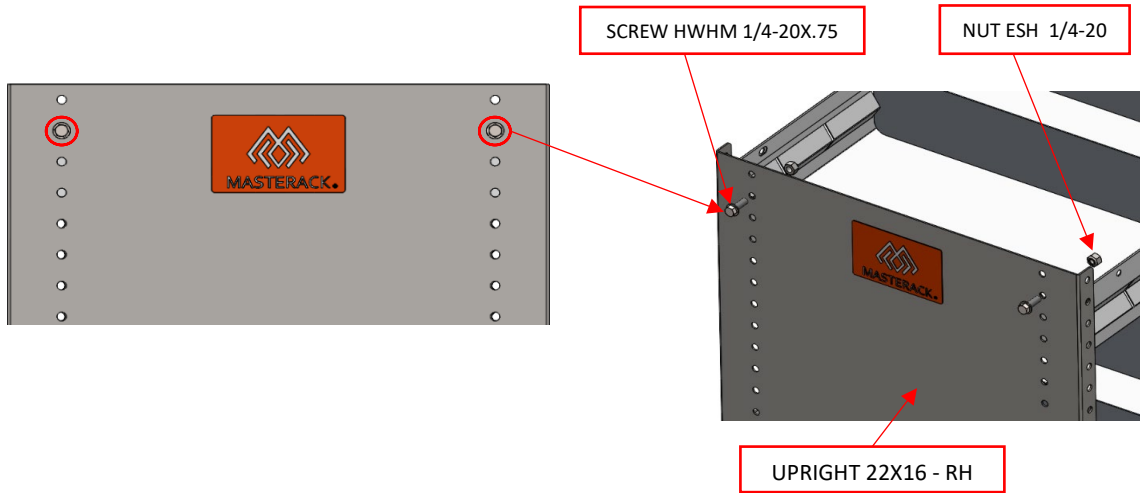

- Assemble two PARTS TRAY 16X37 between the uprights at appropriate heights as shown below.

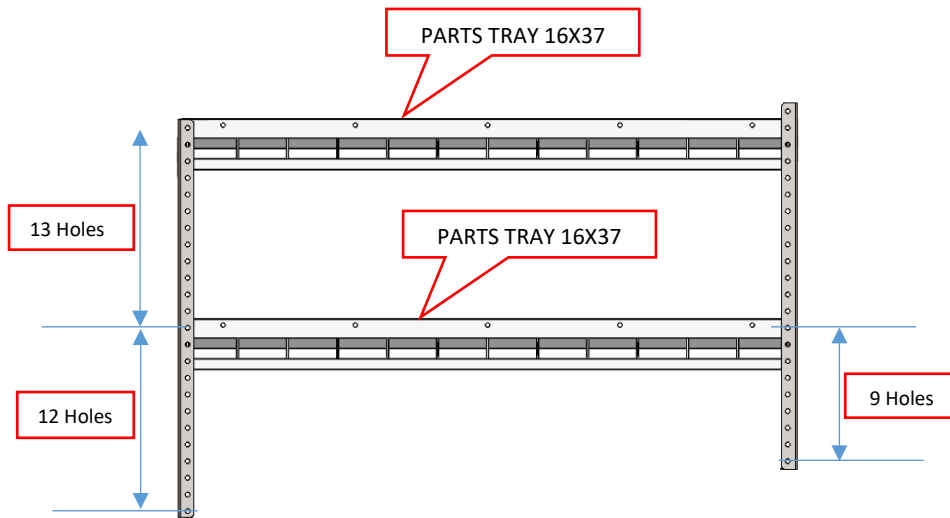

- Below images show mounting position for 028407 – PARTS TRAY between 02P254 and 025885 uprights

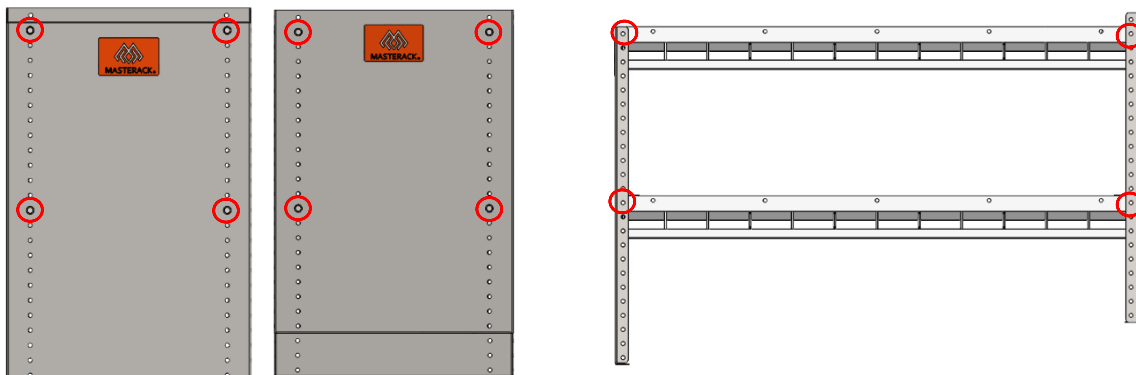

- Assemble tray dividers using the slots provided in the Top and bottom shelf as per the requirement as shown below.

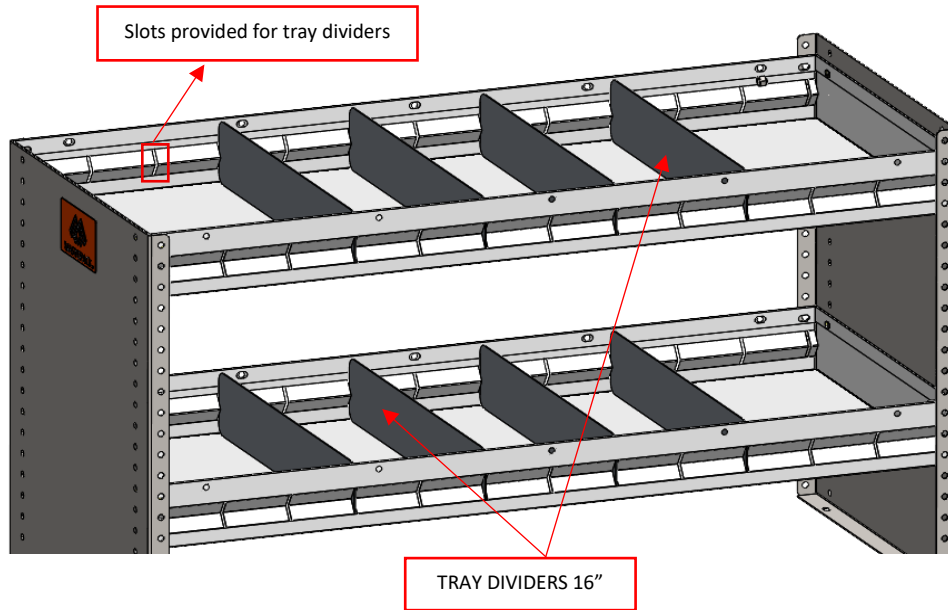

- 4 holes will be drilled on the floor (for LH and RH uprights) of the van using templates. The module will be positioned in the van and installed using (4) 1/4 lock washers, (4) 1/4 flat washers and (4) SCREW HWHM 1/4-20X3/4.

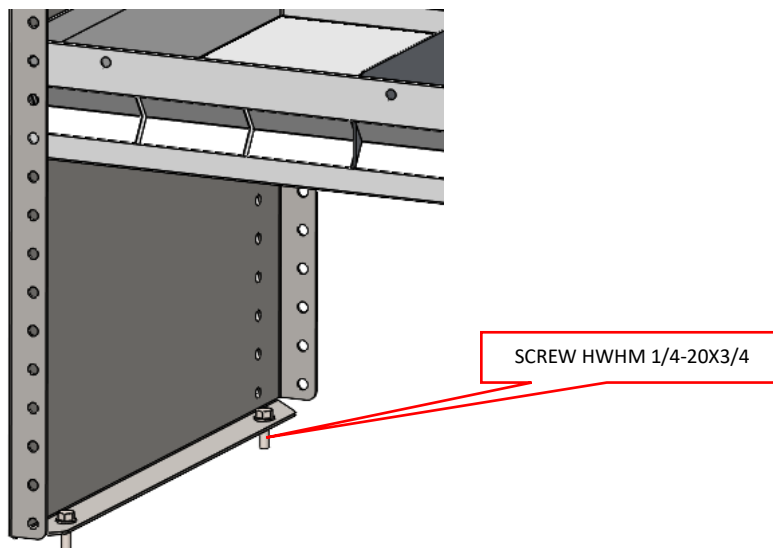

1.4 SIDE SHELVING MODULE ASSEMBLY (02U203KP) - KICKS

- Use SCREW HWHM 1/4-20X.75 and NUT ESH 1/4-20 for assembling parts.
- Attach SHELF METAL 16X25 between two uprights using holes.

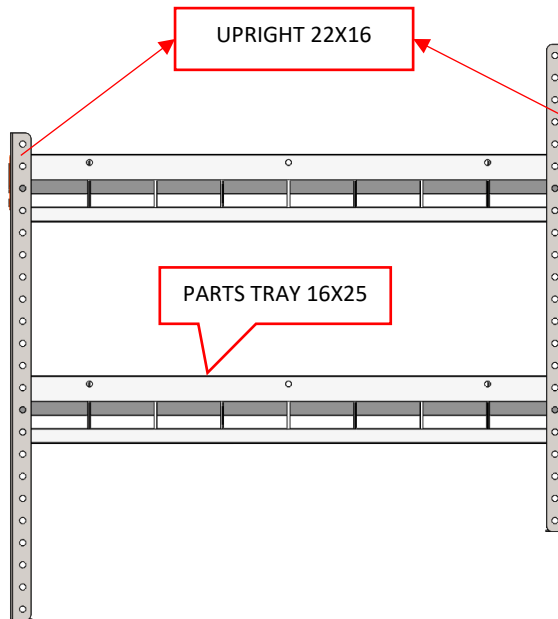

- Take UPRIGHT 22X16 – LH (025885)
- Use the 6th hole from the top on the upright 025885 Upright (LH) to mount the top shelf, as shown in the image below

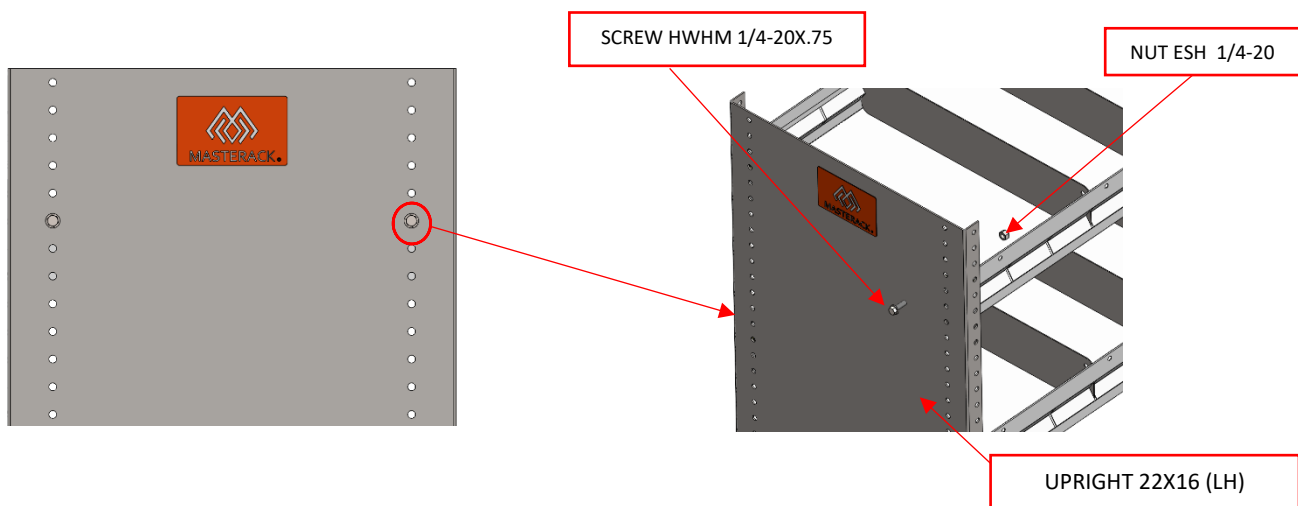

- Take UPRIGHT 22X16 – RH (025885)
- Use the 2nd hole from the top on the upright 025885 (RH) to mount the top shelf, as shown below.

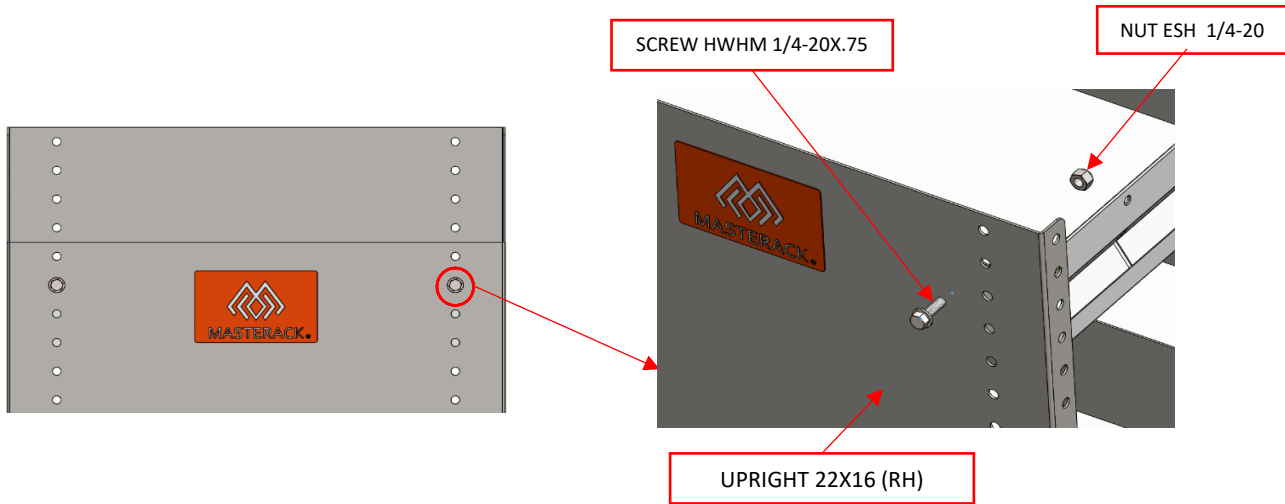

- Assemble two PARTS TRAY 16X25 between the uprights at appropriate heights as shown below.

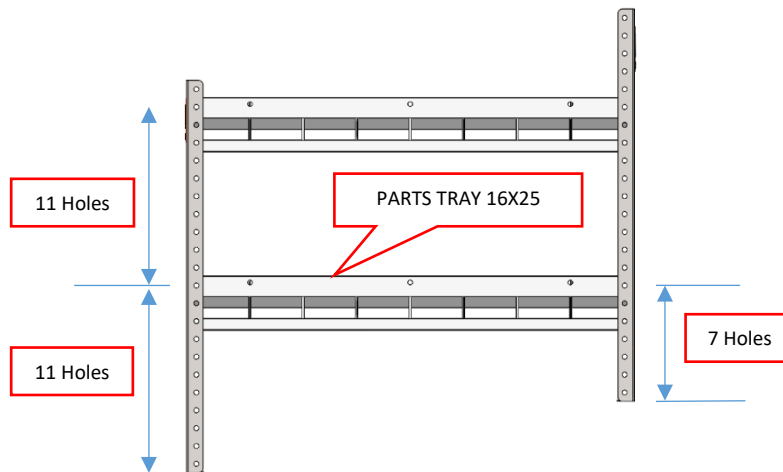

- Images show mounting position for 028405 – PARTS TRAY between 025885 uprights

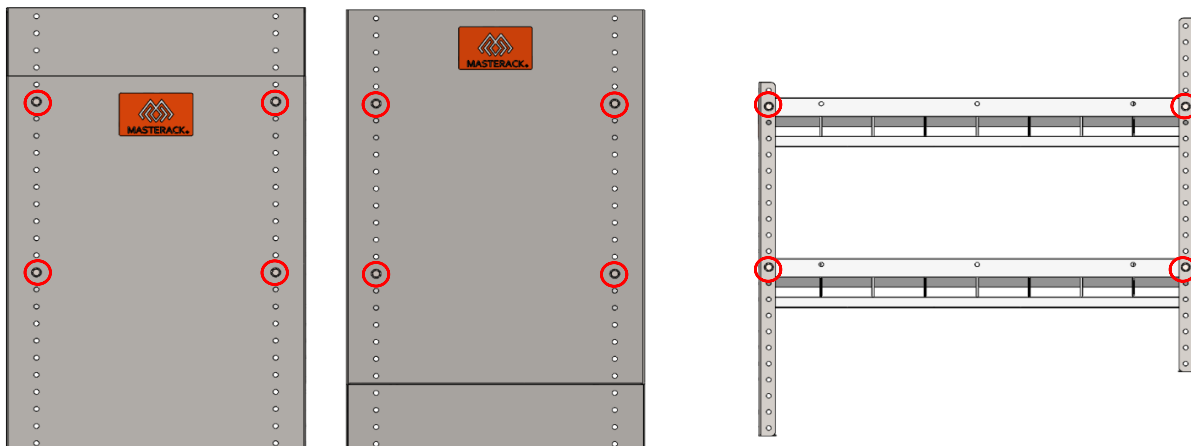

- Assemble tray dividers using the slots provided in the Top and bottom shelf as per the requirement as shown below.

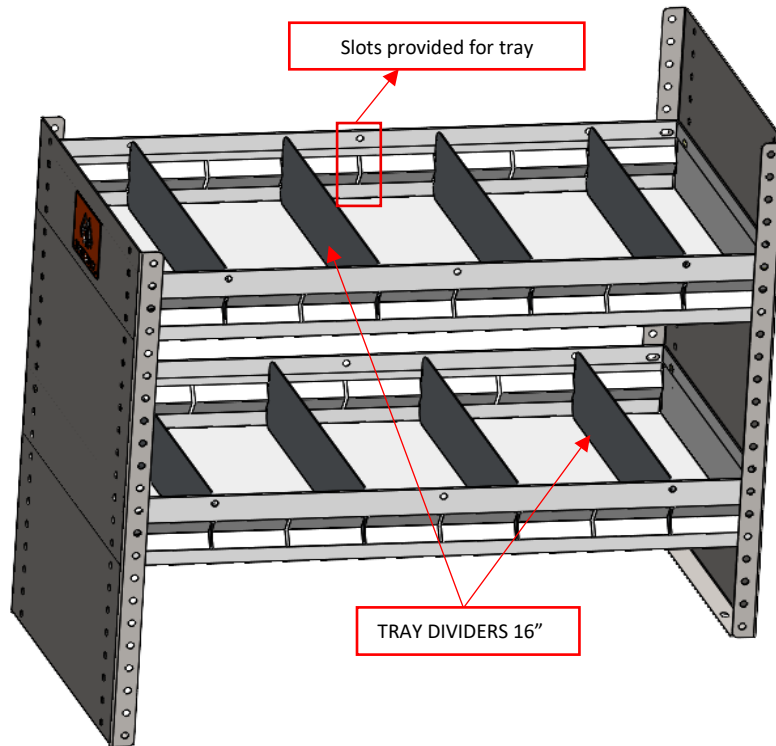

- 4 holes will be drilled on the floor (for LH and RH uprights) of the van using templates. The module will be positioned in the van and installed using (4) 1/4 lock washers, (4) 1/4 flat washers and (4) SCREW HWHM 1/4-20X3/4.

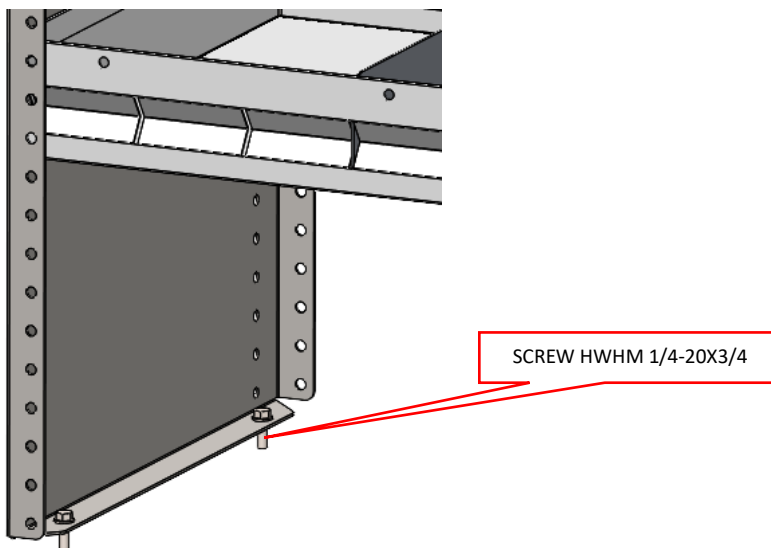

2.1 SHELVING MODULE INSTALLATION NISSAN PATHFINDER

- Position the shelving module one at a time against the partition in the required location as shown in the image below. (**This action requires 2 people to handle**). Repeat the same for the curb side as well.
- Insert RM511458 (bolt) and RM541013 (washer) and loosely tighten. Do the same for all 4 mounting locations.

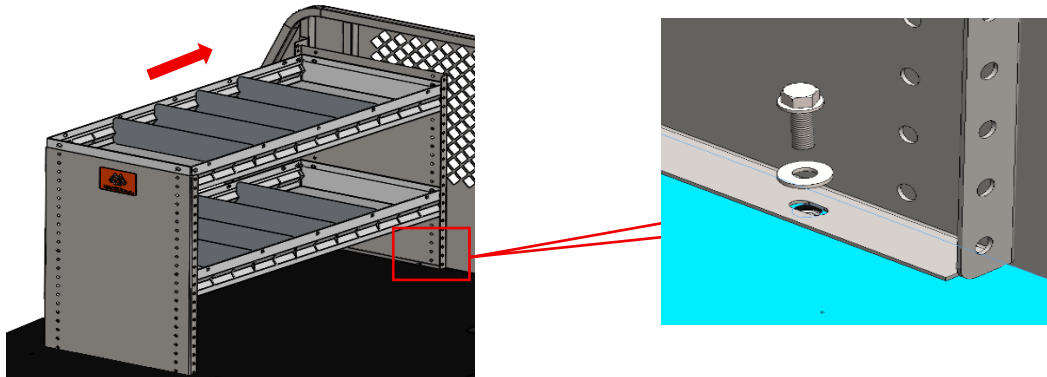

- Position 02U043 - MTG BRKT FRT PRT NF2 (2 Nos.) on the UPR SOL 22"x16" upright of roadside and curbside as shown in the image below.

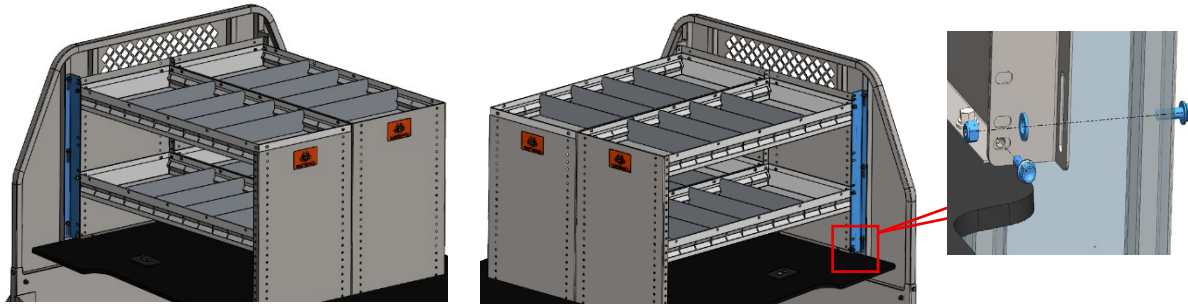

Roadside view

Curbside view

- Use the 2nd slot from the top on the mounting bracket, align it with the first hole on the upright, and attach it to the partition as shown in the images below.

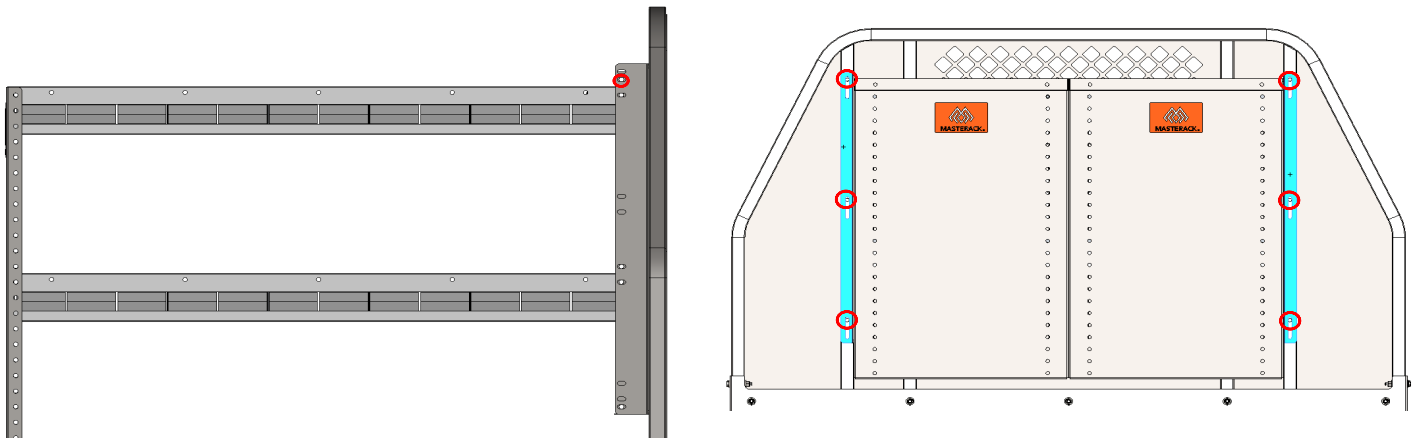

- Insert the fasteners through the aligned holes and loosely secure the bracket to the partition.
- **Hardware needs to be removed from the side shelving at the locations where they are attached to each other and then fastened using screws and nuts as shown below.**

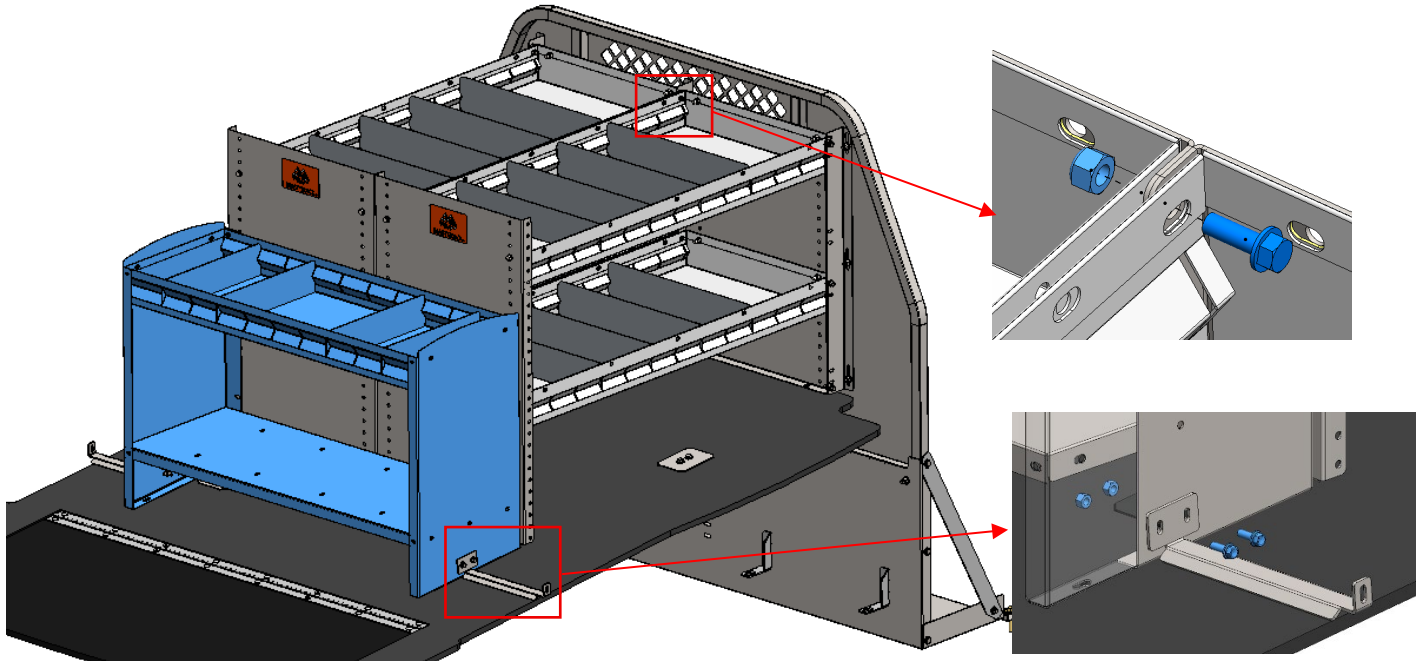

- Position the rear module on the vehicle floor in front of the rear shelving assembly, as shown above.
- Slide the module toward the rear shelving until the side panel aligns flush with the adjacent shelving upright.
- Align the side mounting holes of the rear module with the matching holes on the rear shelving upright.
- Loosely install the fasteners through the aligned side holes to connect the rear module to the rear shelving.
- Attach the 02U047 (Rear mounting brackets) to the rear module upright on either side using bolts and nuts as shown.

Note: Other side of the bracket is attached to the D-ring available on the vehicle with existing hardware.

- Tighten all fasteners securely after confirming fitment.

NOTE:

- 1. If the customer orders only one side module for their van, it is recommended to install it either on the roadside or curbside.**
- 2. If the customer orders the rear shelving module, they must also order two side shelving modules for proper installation.**
- 3. For additional information, please contact the respective Masterack Sales Team.**

2.2 SHELVING MODULE INSTALLATION NISSAN ROGUE

- Position the shelving module one at a time against the partition in the required location as shown in the image below. (This action requires 2 people to handle). Repeat the same for the curb side as well.
- Insert RM511458 (bolt) and RM541013 (washer) and loosely tighten. Do the same for all 4 mounting locations.

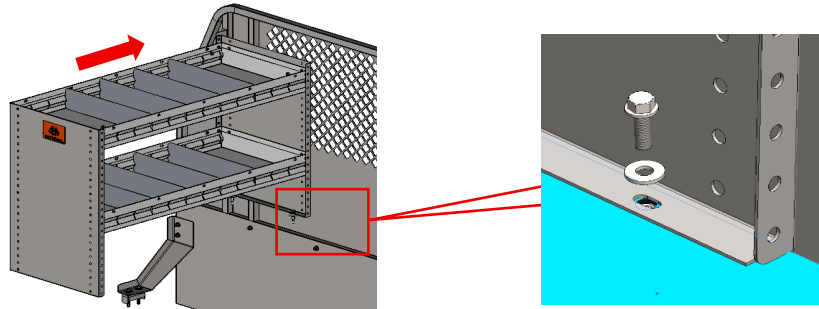

- Position 02U043 - MTG BRKT FRT PRT NF2 (2 Nos.) on the UPR SOL 22"x16" upright of roadside and curbside as shown in the image below.

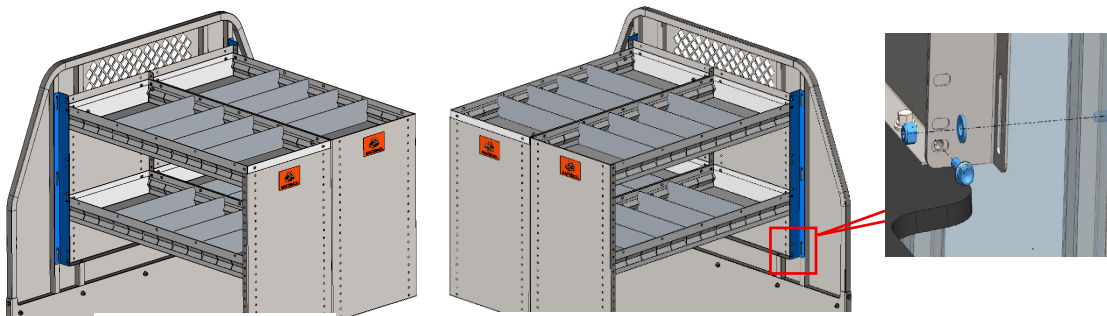

Roadside view

Curb side view

- Use the 3rd slot from the top on the mounting bracket, align it with the first hole on the upright, and attach it to the partition as shown in the images below.

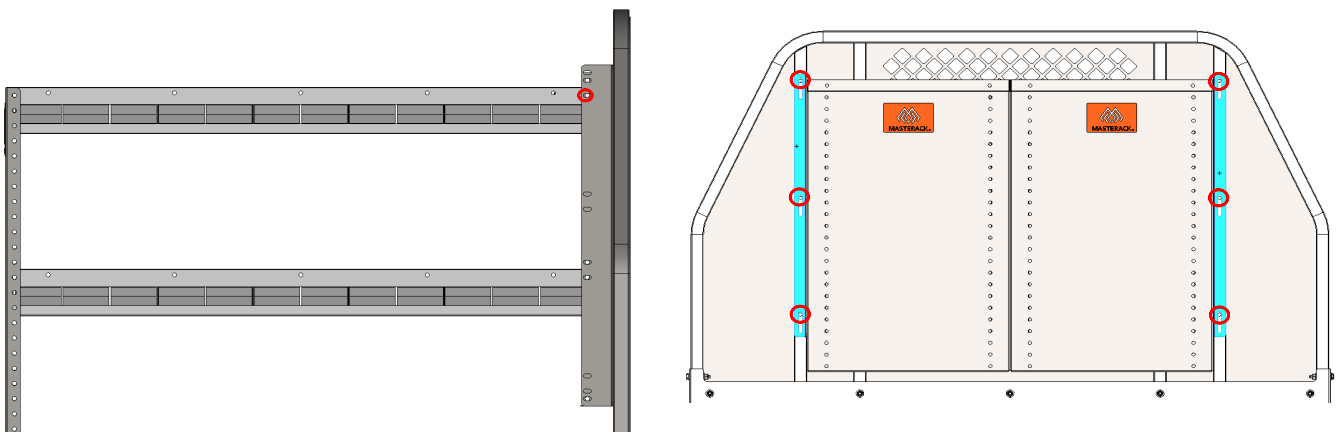

- Insert the fasteners through the aligned holes and loosely secure the bracket to the partition.
- **Hardware needs to be removed from the side shelving at the locations where they are attached to each other and then fastened using screws and nuts as shown below.**

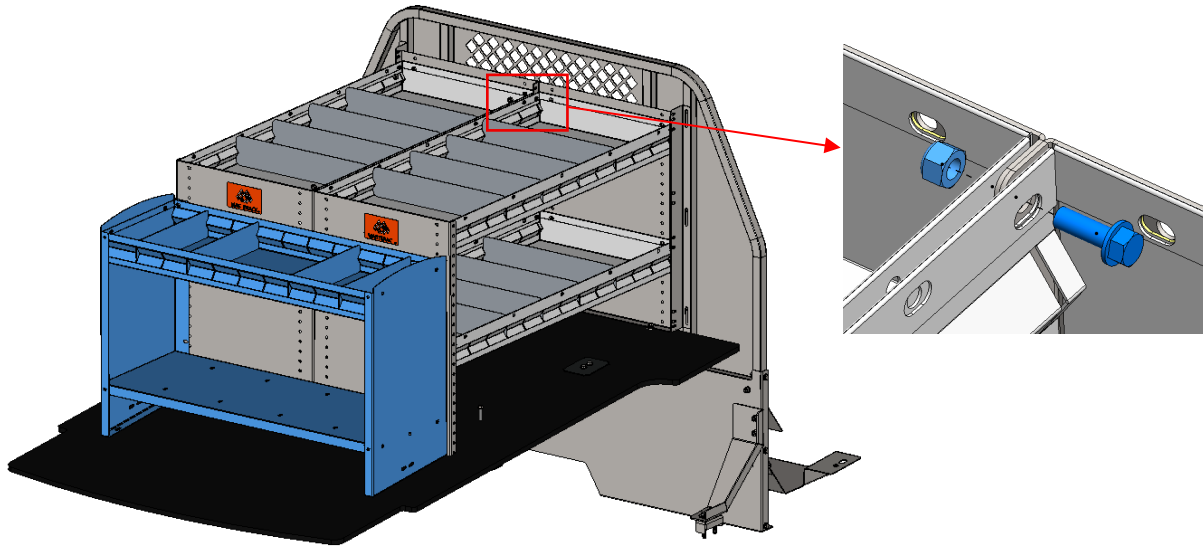

- Position the rear module on the vehicle floor in front of the rear shelving assembly, as shown above.
- Slide the module toward the rear shelving until the side panel aligns flush with the adjacent shelving upright.
- Align the side mounting holes of the rear module with the matching holes on the rear shelving upright.
- Loosely install the fasteners through the aligned side holes to connect the rear module to the rear shelving.
- Tighten all fasteners securely after confirming fitment.

NOTE:

1. **If the customer orders only one side module for their van, it is recommended to install it either on the roadside or curbside.**
2. **If the customer orders the rear shelving module, they must also order two side shelving modules for proper installation.**
3. **For additional information, please contact the respective Masterack Sales Team**

2.3 SHELVING MODULE INSTALLATION NISSAN KICKS

- Position the shelving module one at a time against the partition in the required location as shown in the image below. (**This action requires 2 people to handle**). Repeat the same for the curb side as well.
- Insert RM511458 (bolt) and RM541013 (washer) and loosely tighten. Do the same for all 4 mounting locations.

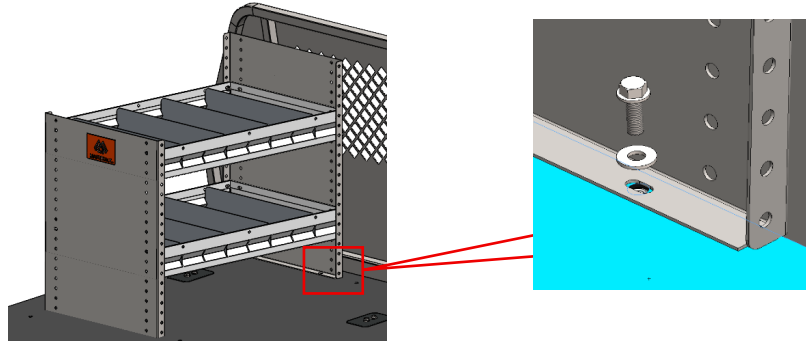

- Position 02U248 - MTG BRKT FRT PRT (2 Nos.) on the UPR SOL 22"x16" upright of roadside and curbside as shown in the image below.

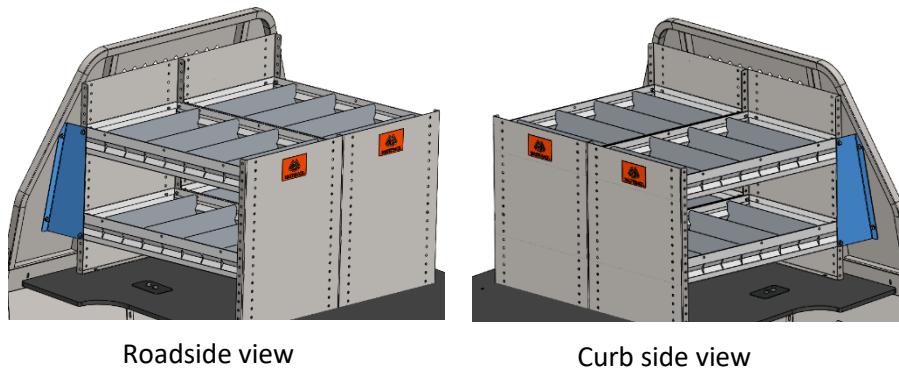

- Use the 1st slot from the top on the mounting bracket, align it with the first hole on the upright, and attach it to the partition as shown in the images below.

•

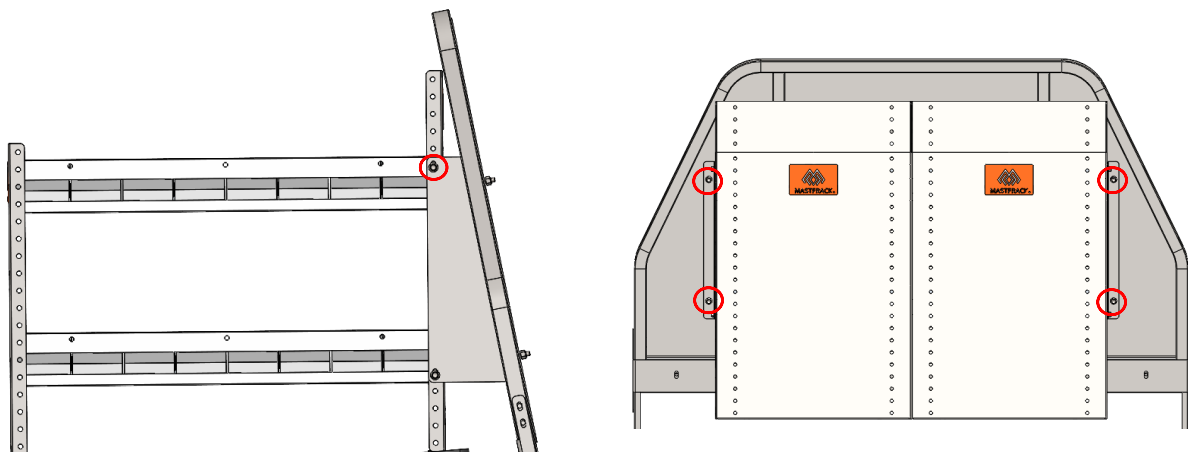

- Insert the fasteners through the aligned holes and loosely secure the bracket to the partition.
- **Hardware needs to be removed from the side shelving at the locations where they are attached to each other and then fastened using screws and nuts as shown below.**

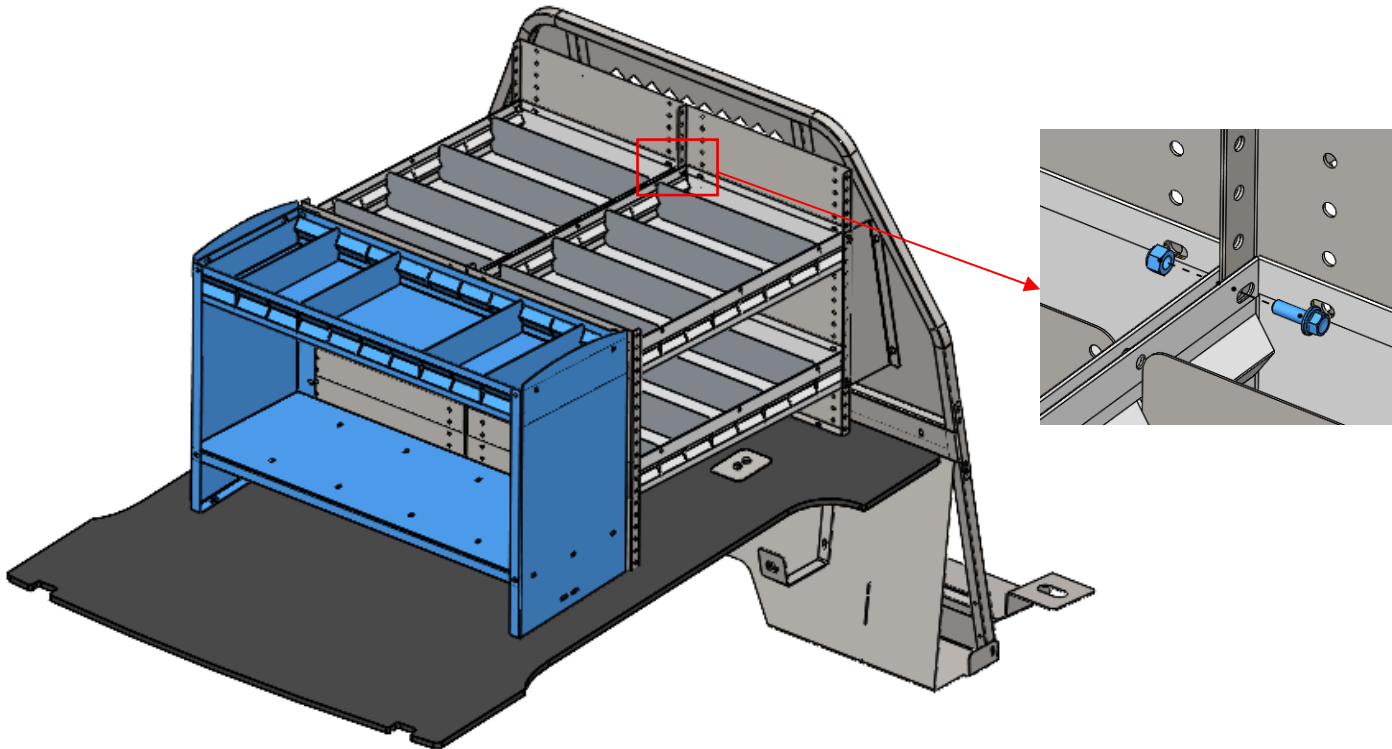

- Position the rear module on the vehicle floor in front of the rear shelving assembly, as shown above.
- Slide the module toward the rear shelving until the side panel aligns flush with the adjacent shelving upright.
- Align the side mounting holes of the rear module with the matching holes on the rear shelving upright.
- Loosely install the fasteners through the aligned side holes to connect the rear module to the rear shelving.
- Tighten all fasteners securely after confirming fitment.

NOTE:

- 1. If the customer orders only one side module for their van, it is recommended to install it either on the roadside or curbside.**
- 2. If the customer orders the rear shelving module, they must also order two side shelving modules for proper installation.**
- 3. For additional information, please contact the respective Masterack Sales Team**