

Recommended Tools

Air or Hand Ratchet



1/2" Socket



1/2" Combo Wrench



7/16" Combo Wrench



6mm Hex Allen Wrench



PN	DESCRIPTION	QTY
02P325	CROSSBEAM ASSEMBLY UPLYFT	1
02P326	CROSSBOW ASSY - FRONT	1
02P328	CONNECTING TUBE	2
02P103	DROP DOWN ASSEMBLY	2
02P393	MIDROOF HANDLE ASSY UPLYFT	1
02P663	LADDER STOP ASSY FRONT	2
02P664	LADDER STOP ASSY REAR	2
02P665	ROTATION ASSEMBLY MR	2
02P666	HARDWARE BAG	1
02R245	MOUNTING RAIL	2
02T110	RAIL EXTRUSION PM LWB FW	2
02P148	RAIL CAP UPLYFT	4
RM518016	SCREW PPHSM 14 X.625	4
02T919	SHIP PACK PM 159 LWB	1
02T921	HDW BAG PM 159 LWB	1

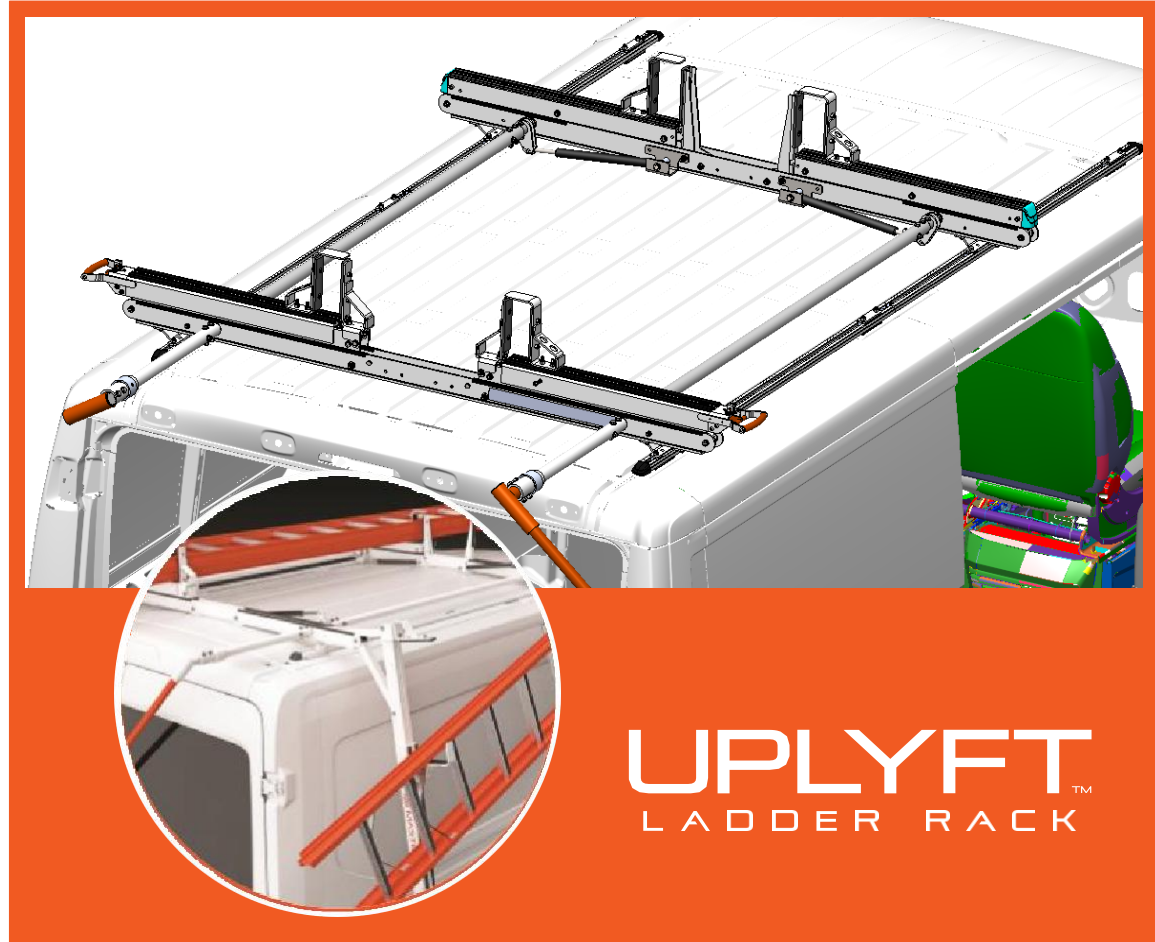

UPLYFT™ LADDER RACK SYSTEM

Before installation, review this document to ensure that all parts and hardware are included in the package.

In the event that parts are missing, please contact Masterack at 1-800-222-8785 to re-order missing parts.

BEFORE INSTALLATION PLEASE REVIEW THIS ENTIRE DOCUMENT, UNTIL YOU ARE COMPLETELY FAMILIAR WITH ALL STEPS BEFORE BEGINNING. A "PRACTICE RUN" OF THESE STEPS/PROCEDURES MAY BE HELPFUL TO ASSIST YOU IN FAMILIARIZING YOURSELF THOROUGHLY AND AVOID COSTLY ERRORS.

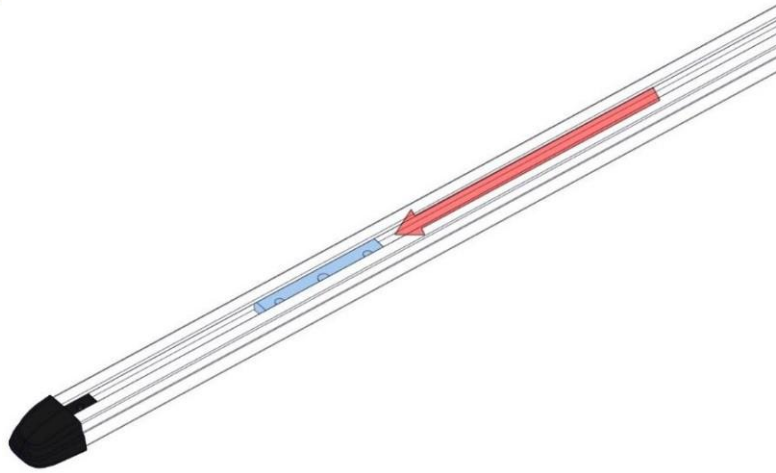
**Step 1.**

Slide receiver block (02P118) into both mounting rails (02R245 and 02T110) one into each of the four rails.

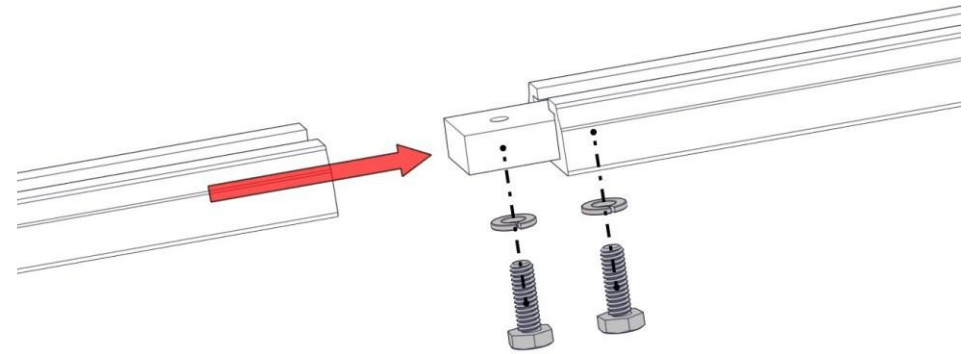
**Step 2.**

Slide joining block (02P125) into channels. Fasten with 1/4" lock washers and 1/4" X 1" hex bolts. Tighten with 7/16" wrench.

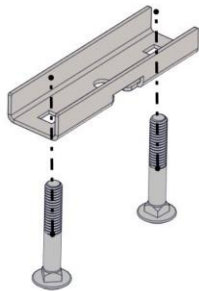
**Step 3.**

Install 2 of the 5/16" x 2" bolts into base bracket (repeat 6 times).

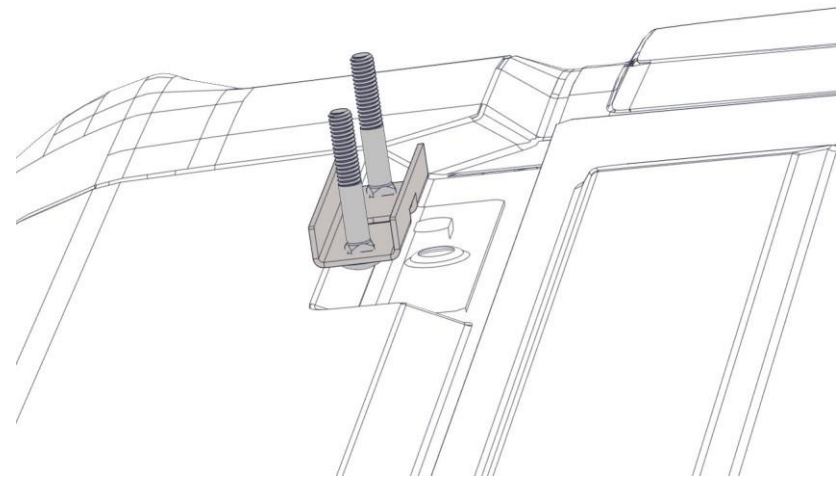
**Step 4.**

Install base brackets on vehicle by locating mounting tabs on top of vehicle. Pull tabs up and slide the bracket underneath. Repeat for all 6 locations.

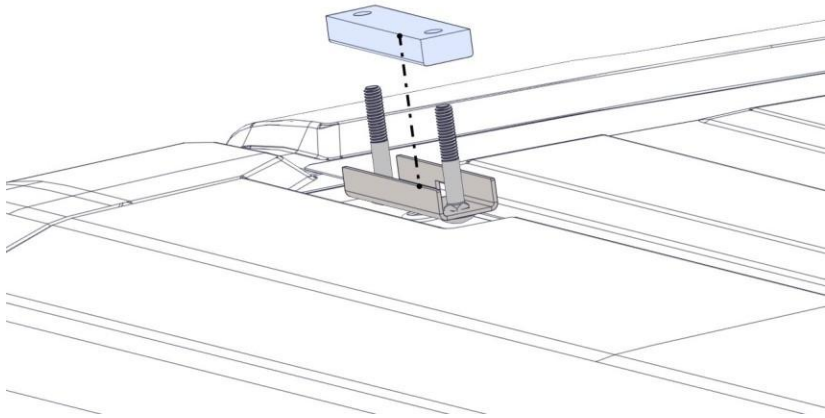

Step 5.
Install spacer inside base brackets. Repeat for all 6 locations.

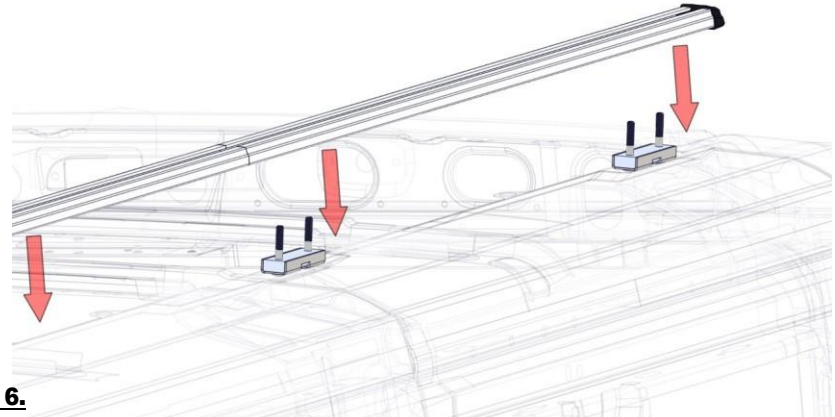

Step 6.
Place rails on top of vehicle and slide receiver blocks from Step 1 all the way forward.

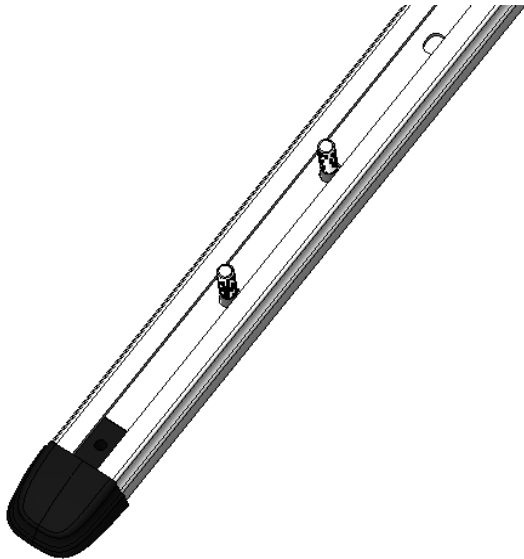

Step 7.1
Starting at the rear of the vehicle, use the first hole as shown. Use the 02T110 rail for the rear side of the vehicle.

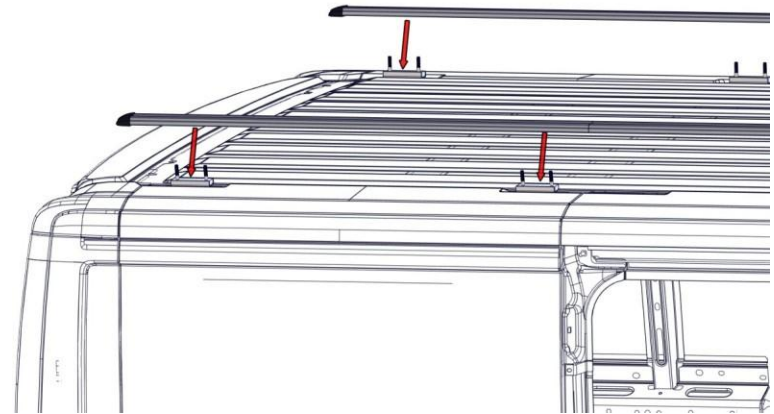

Step 7.2
Place the rail on top of the base brackets.

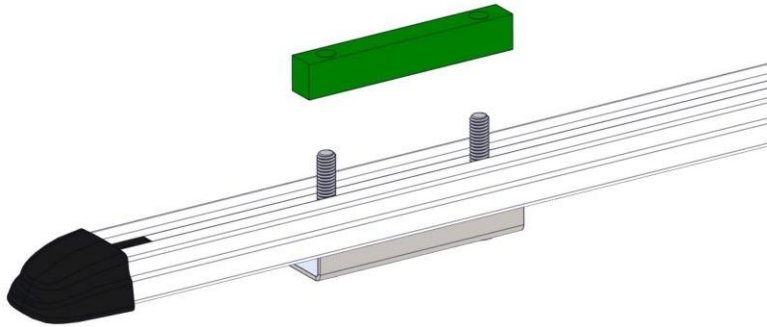

Step 8.

Install bolt spacers as shown over the bolts inside the channel. Repeat the same for 6 locations.

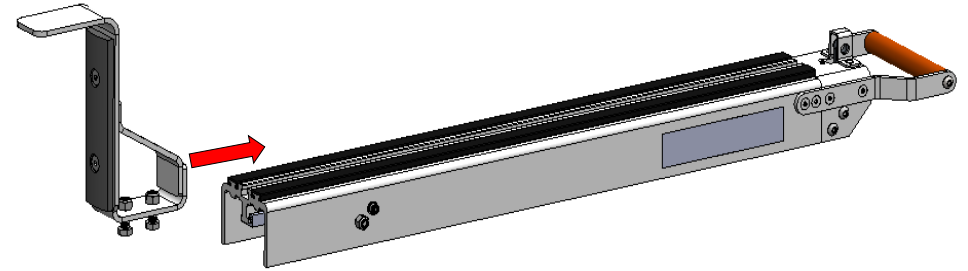

Step 9.

Slide ladders stop (02P663) inside drop down and tighten with 9/16 socket or wrench.

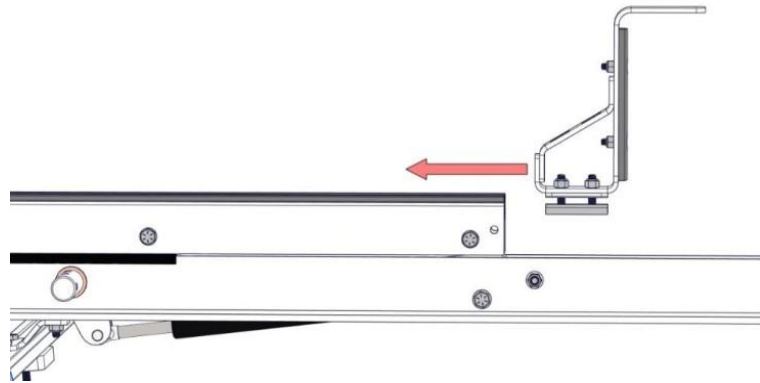

Step 10.

Slide ladders stop (02P664) tighten bolts using 9/16 socket or wrench.

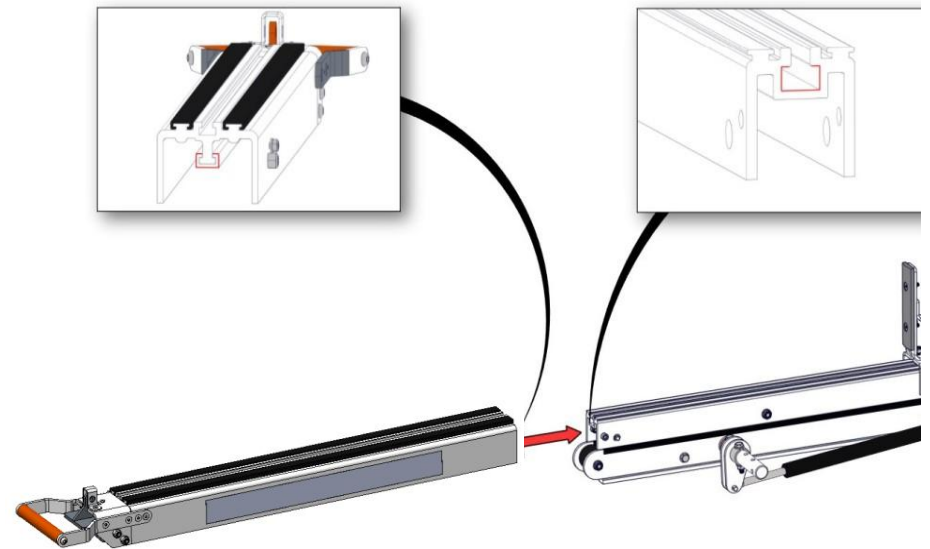

Step 11.

Slide the drop-down assembly into a crossbow by lining up the extrusion, and slide in.

IMPORTANT TO NOTE:

A BLUE sticker indicates the FRONT Crossbows (02P326)



A GREEN sticker indicates the REAR Crossbows (02P325)

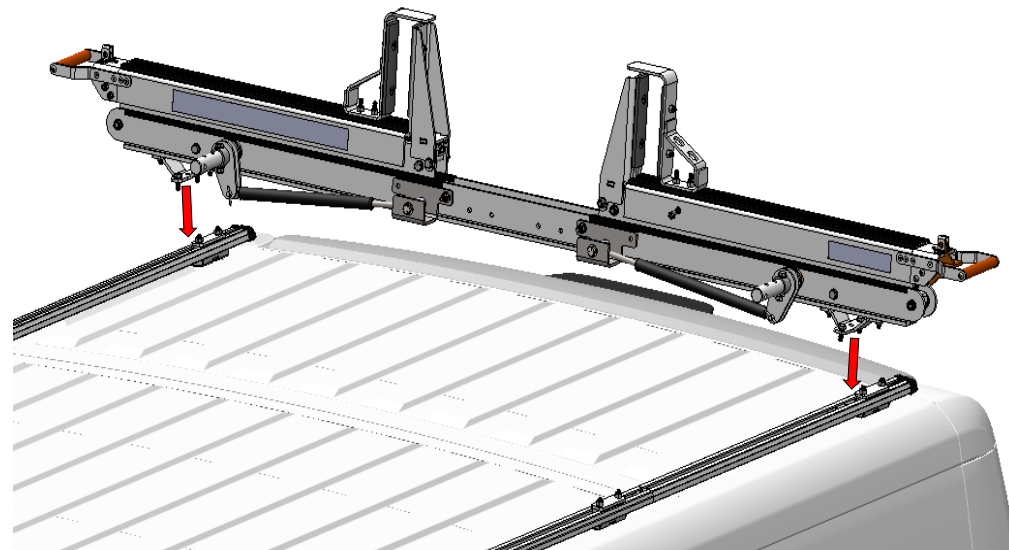

Step 12.

Lay rear crossbow across mounting rails

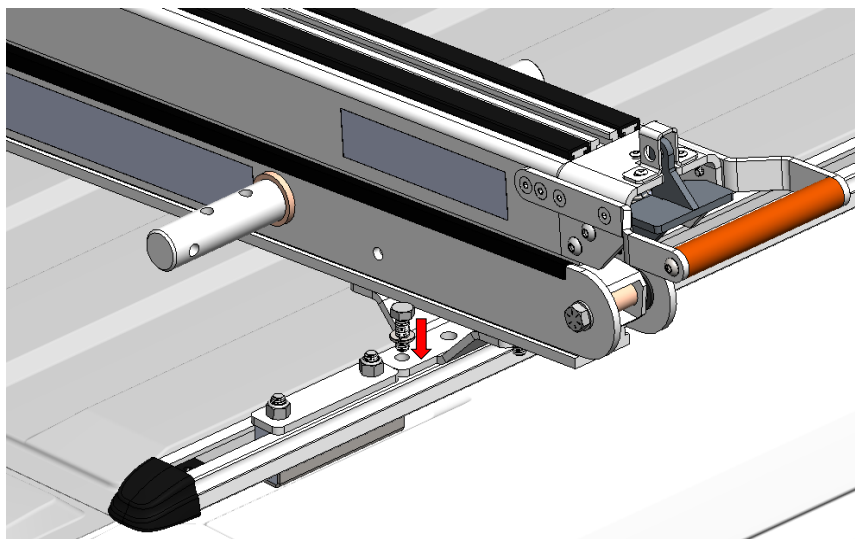

Step 13.

Install 5/16 X 7/8 bolts (4) with lock washers (4) through crossbow mounts into receiver blocks and apply seize to bolts Do not tighten

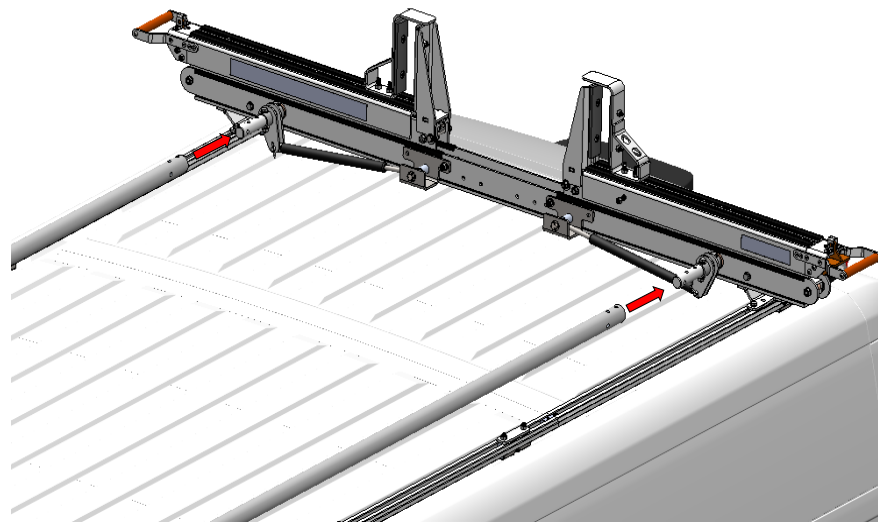

Step 14.

Slide connecting tubes 02P328 into the rear crossbow assembly

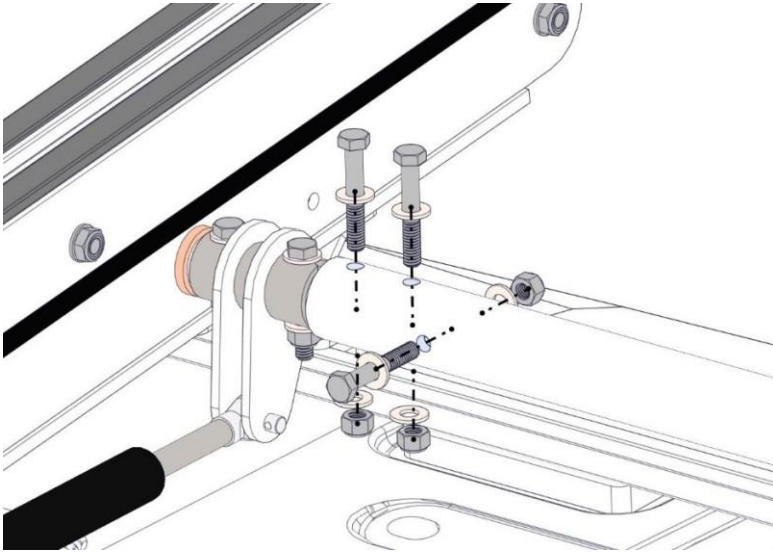

Step 15.
Install connecting tubes with 5/16" X 2 - 1/2" fasteners (6), washers (12), nuts (6) and apply anti seize to bolts

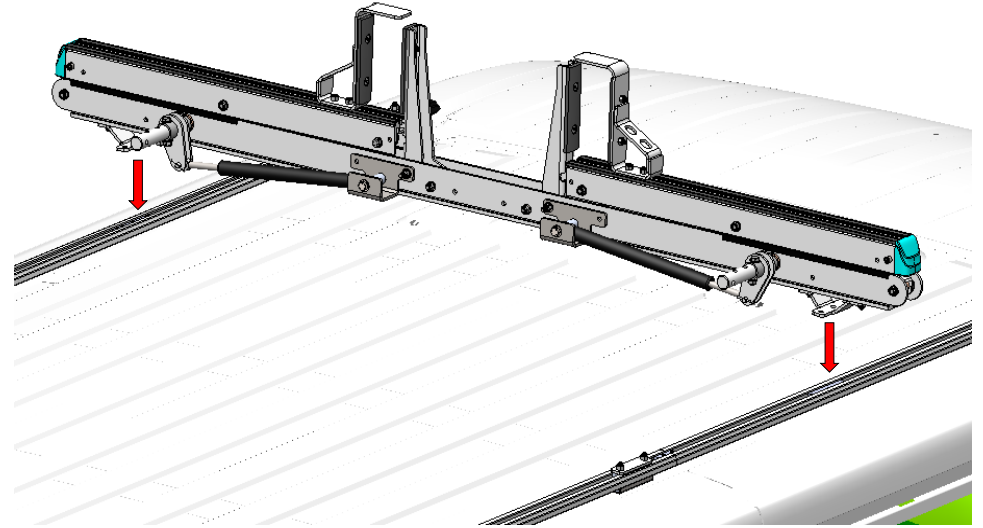

Step 16.
Lay front crossbow across mounting rails

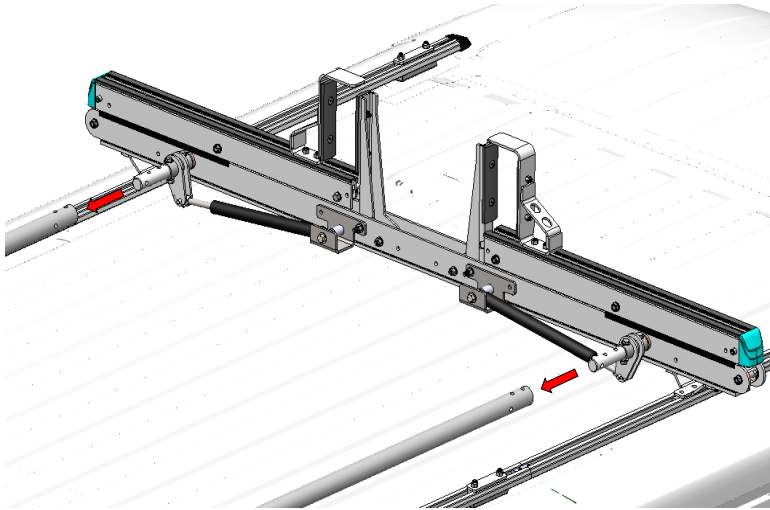

Step 17.
Slide front crossbow into connecting tubes and attach connecting tubes (2) with 5/16" x 2" bolts (R511497).

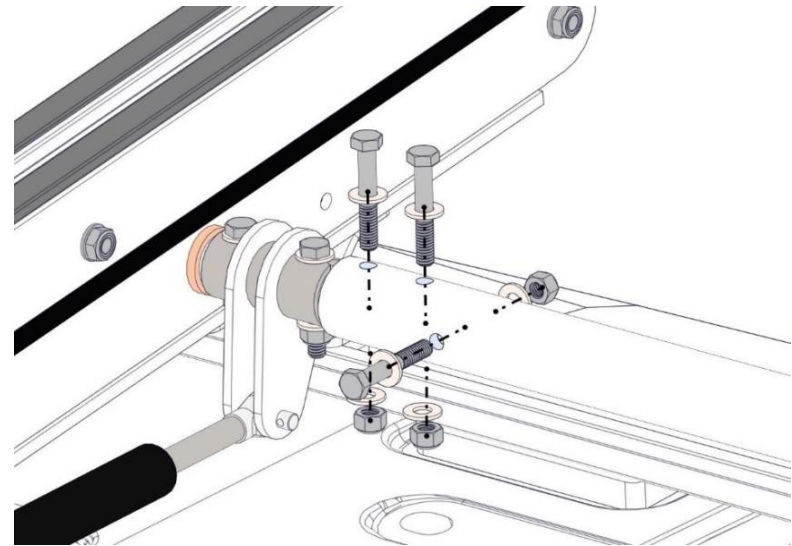

Step 18.
Install connecting tubes with 5/16" X 2 - 1/2" fasteners (6), washers (12), nuts (6) and apply anti seize to bolts

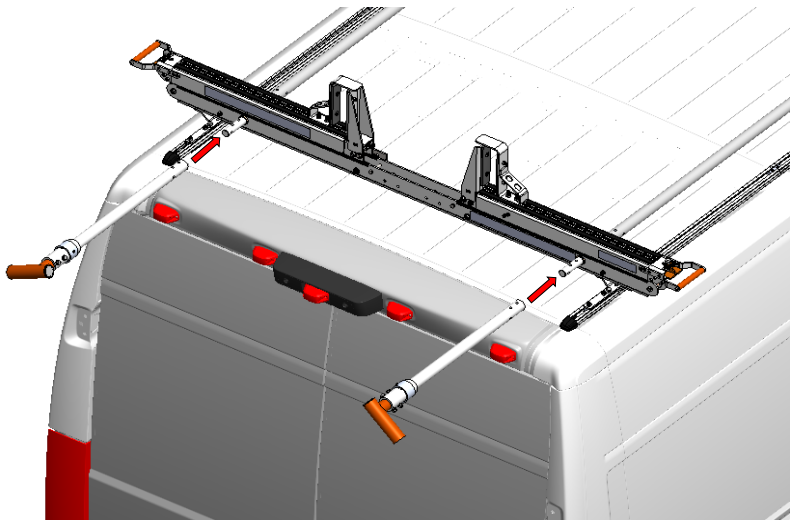

Step 19.
Install handle assembly into rear crossbow as shown

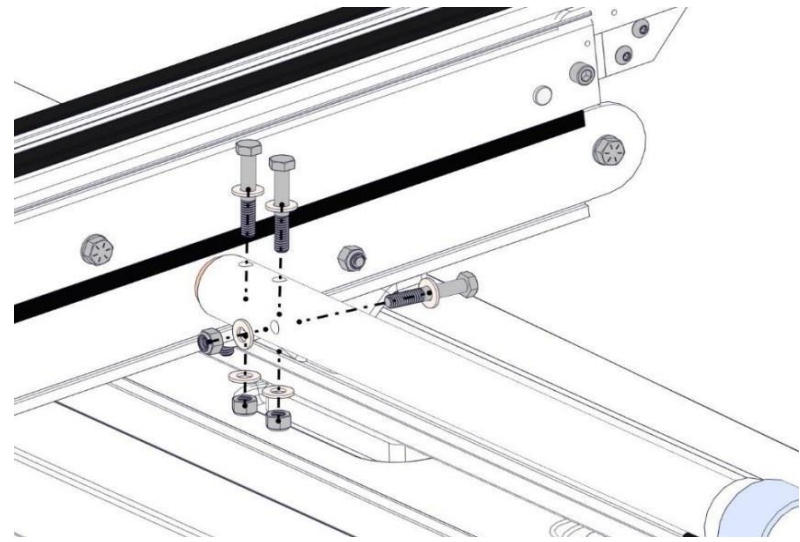

Step 20.
Fasten handles with 5/16 X 2-1/2 bolts (6), washers (12), nuts (6) and apply anti seize to bolts.

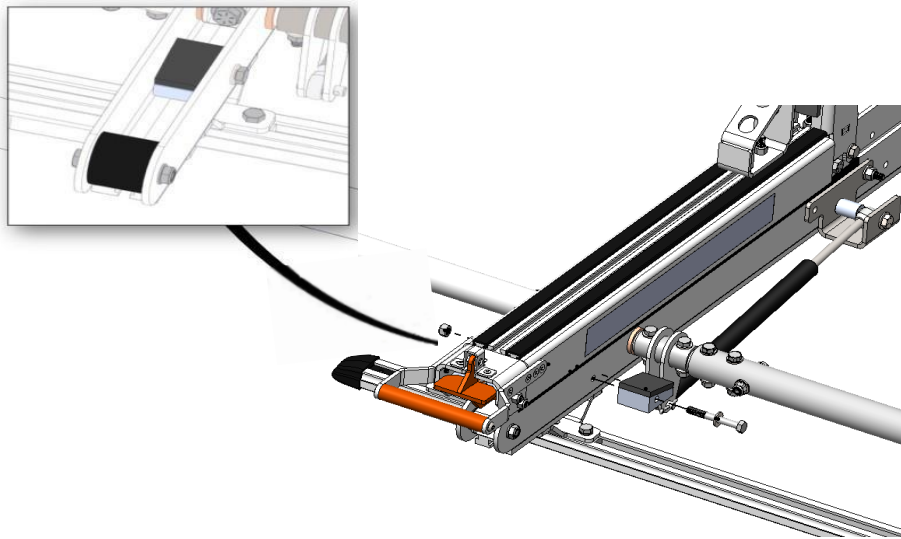

Step 21.
Install ladder stops (4) on curbside and roadside crossbows using 5/16" x 2-1/2" bolts, washer, bumper stop and nut and tighten with a 1/2" wrench

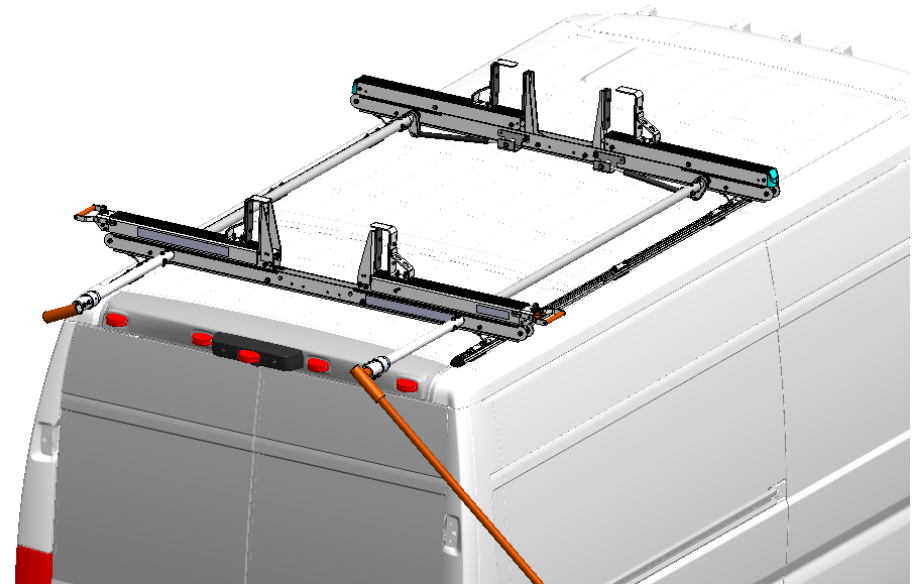

Step 22.
Assembly after installation