

Recommended Tools

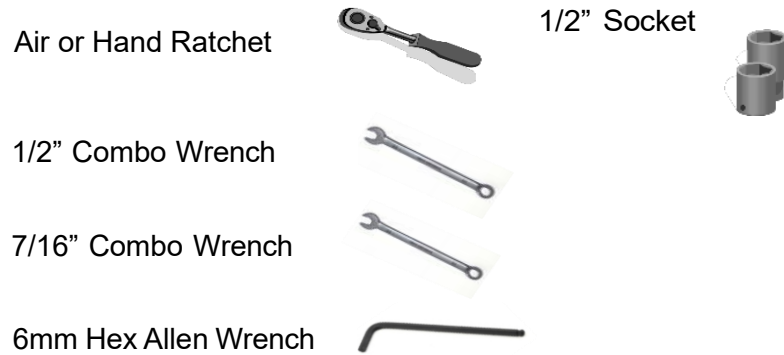

PN	DESCRIPTION	QTY
02P675	CROSSBOW ASSY – REAR	1
02P676	CROSSBOW ASSY - FRONT	1
02P665	ROTATION ASSEMBLY MR	1
02P328	CONNECTING TUBE - PWDR UPLYFT	1
02P103	DROP DOWN ASSEMBLY UPLYFT	1
02P663	LADDER STOP ASSY FRONT UPLYFT	1
02P664	LADDER STOP ASSY REAR UPLYFT	1
02P677	HARDWARE BAG UPLYFT SINGLE	1
02P393	MIDROOF HANDLE ASSY UPLYFT	1
02R245	MOUNTING RAIL	2
02T110	RAIL EXTRUSION PM LWB FW	2
02P148	RAIL CAP UPLYFT	4
RM518016	SCREW PPHSM 14 X.625	4
02T919	SHIP PACK PM 159 LWB	1
02T921	HDW BAG PM 159 LWB	1

UPLYFT™ LADDER RACK SYSTEM

Before installation, review this document to ensure that all parts and hardware are included in the package.

In the event that parts are missing, please contact Masterack at 1-800-222-8785 to re-order missing parts.

BEFORE INSTALLATION PLEASE REVIEW THIS ENTIRE DOCUMENT, UNTIL YOU ARE COMPLETELY FAMILIAR WITH ALL STEPS BEFORE BEGINNING. A "PRACTICE RUN" OF THESE STEPS/PROCEDURES MAY BE HELPFUL TO ASSIST YOU IN FAMILIARIZING YOURSELF THOROUGHLY AND AVOID COSTLY ERRORS.

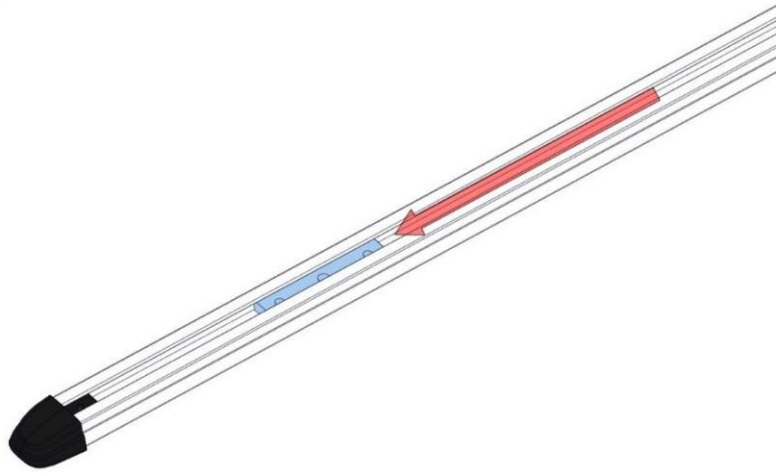
**Step 1.**

Slide receiver block (02P118) into both mounting rails (02R245 and 02T110) one into each of the four rails.

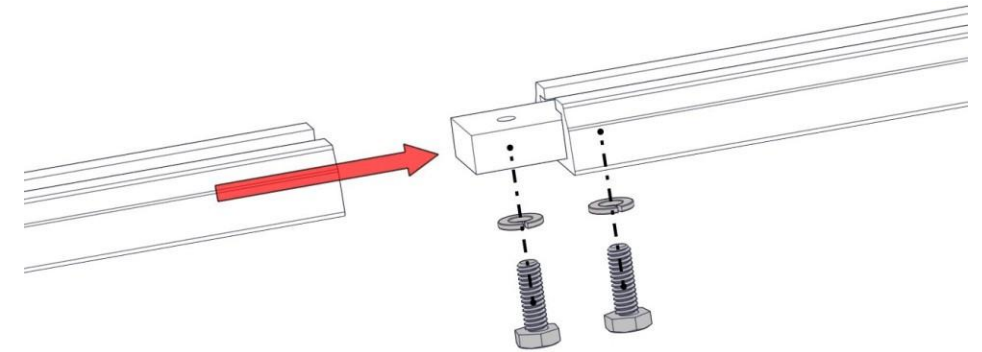
**Step 2.**

Slide joining block (02P125) into channels. Fasten with 1/4" lock washers and 1/4" X 1" hex bolts. Tighten with 7/16" wrench.

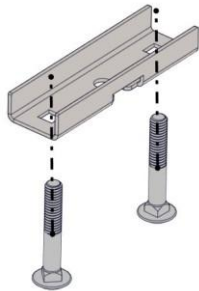
**Step 3.**

Install 2 of the 5/16" x 2" bolts into base bracket (repeat 6 times).

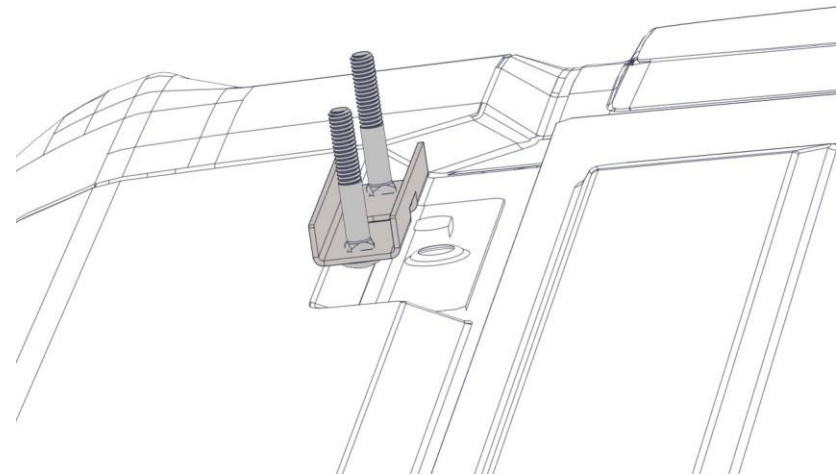
**Step 4.**

Install base brackets on vehicle by locating mounting tabs on top of vehicle. Pull tabs up and slide the bracket underneath. Repeat for all 6 locations.

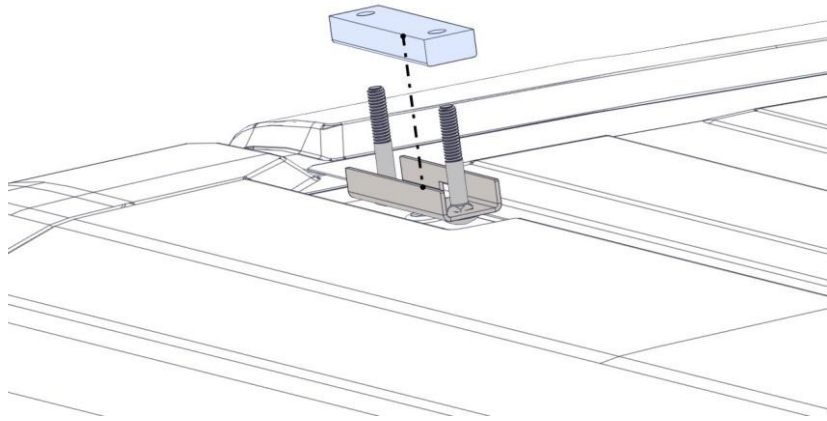

Step 5.
Install spacer inside base brackets. Repeat for all 6 locations.

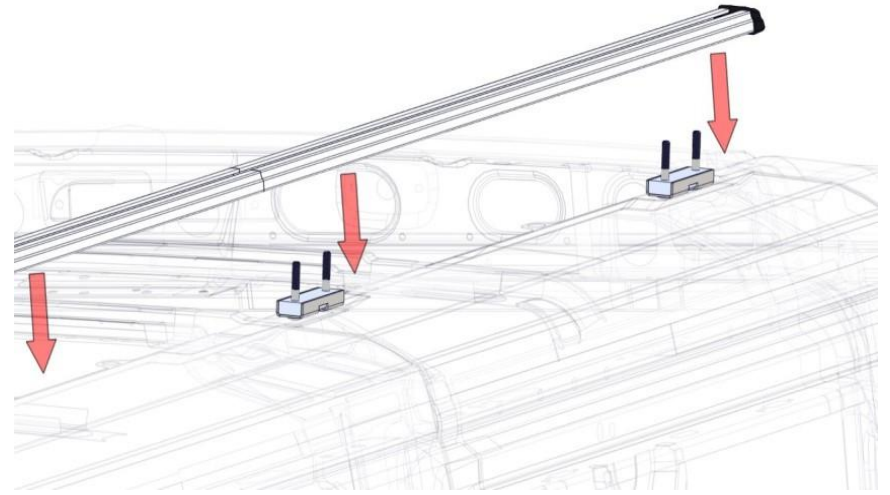

Step 6.
Place rails on top of vehicle and slide receiver blocks from Step 1 all the way forward.

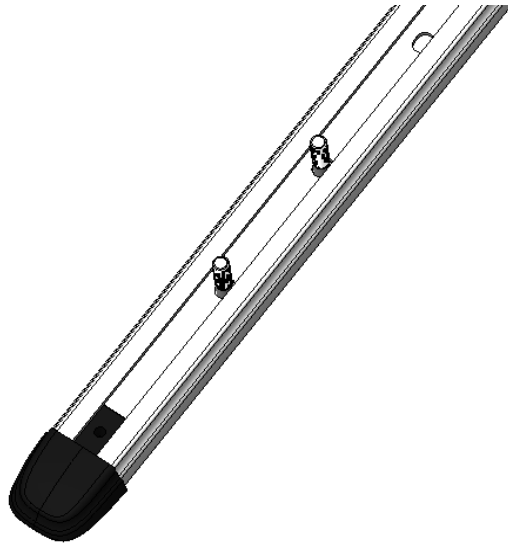

Step 7.1
Starting at the rear of the vehicle, use the first hole as shown. Use the 02T110 rail for the rear side of the vehicle.

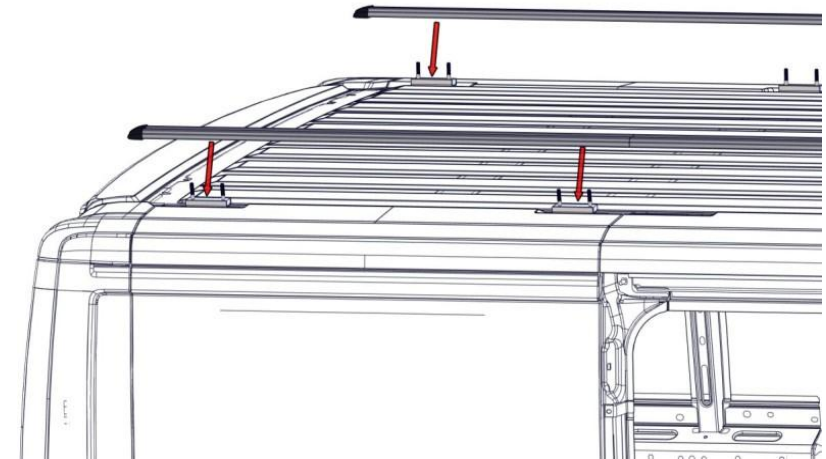

Step 7.2
Place the rail on top of the base brackets.

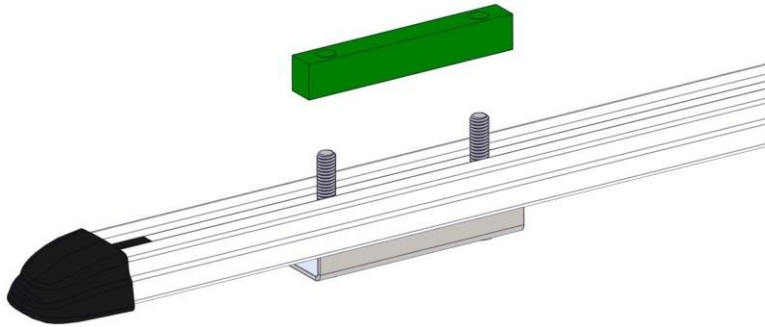

Step 8.

Install bolt spacers as shown over the bolts inside the channel. Repeat for all 6 locations.

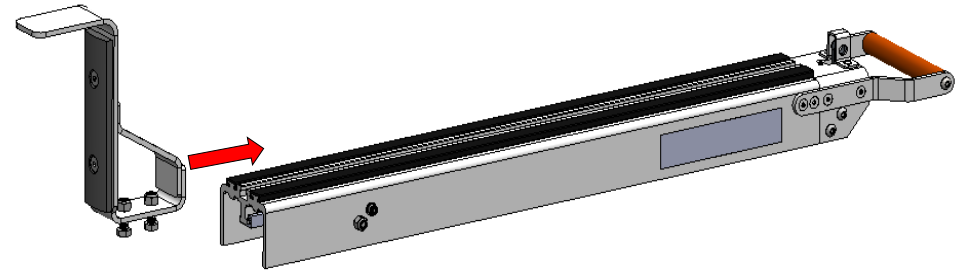

Step 9.

Slide ladders stop (02P663) inside drop down and tighten with 9/16 socket or wrench.

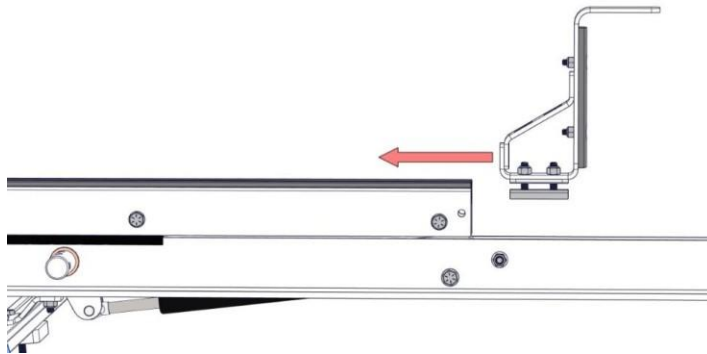

Step 10.

Slide ladders stop (02P664) tighten bolts using 9/16 socket or wrench.

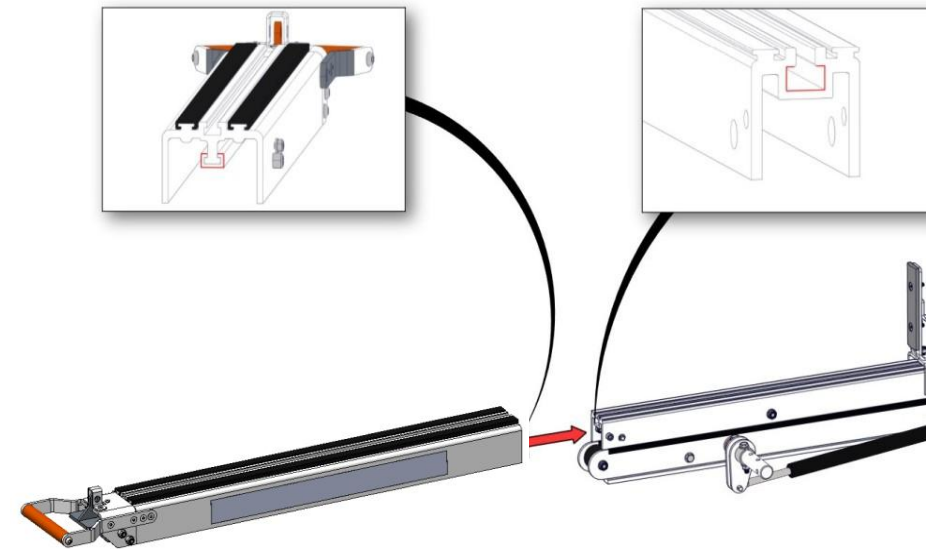

Step 11.

Slide the drop-down assembly into a crossbow by lining up the extrusion, and slide in.

IMPORTANT TO NOTE:

A BLUE sticker indicates the FRONT Crossbows (02P676)



A GREEN sticker indicates the REAR Crossbows (02P675)

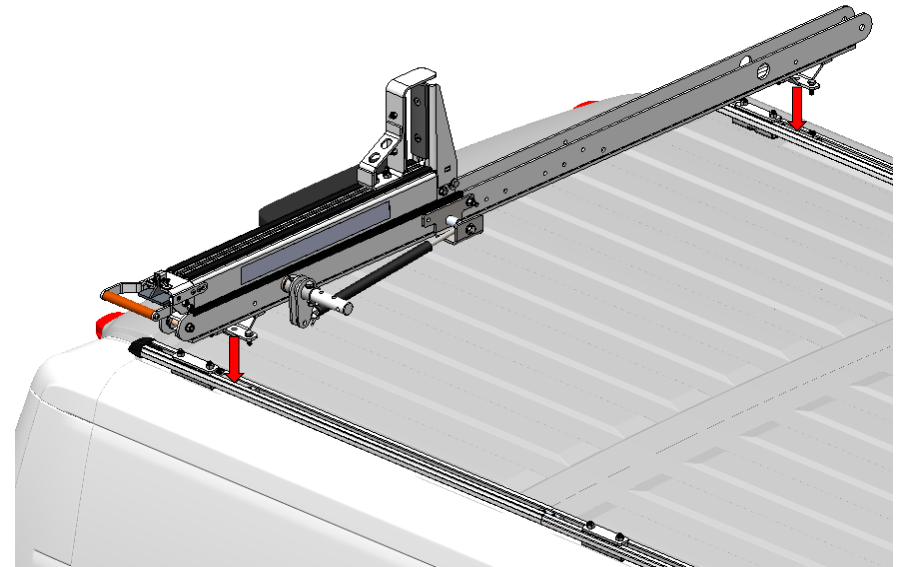

Step 12.

Lay rear crossbow across mounting rails

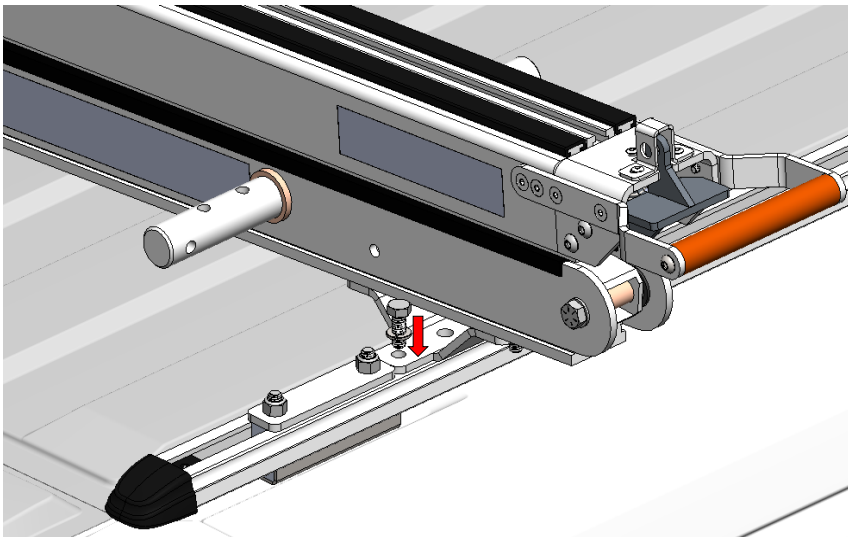

Step 13.

Install 5/16 X 7/8 bolts (4) with lock washers (4) through crossbow mounts into receiver blocks and apply seize to bolts Do not tighten

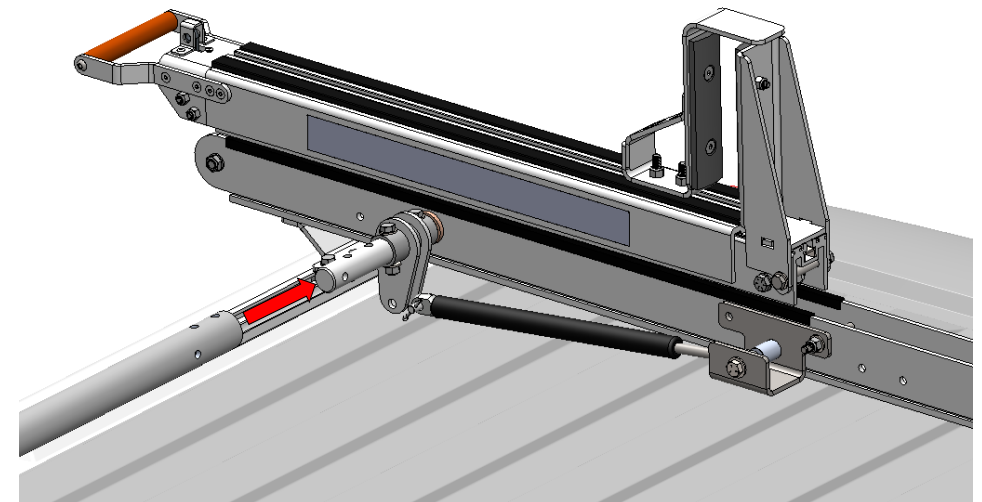

Step 14.

Install the connecting tube 02P328 into the rear crossbow assembly.

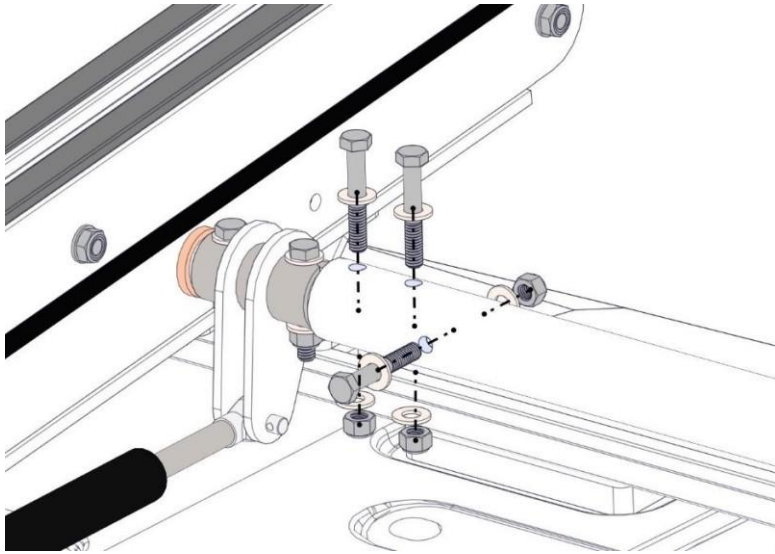

Step 15.

Install connecting tube with 5/16 X 2-1/2 fasteners (3) & washers (6).
apply anti-seize to bolts

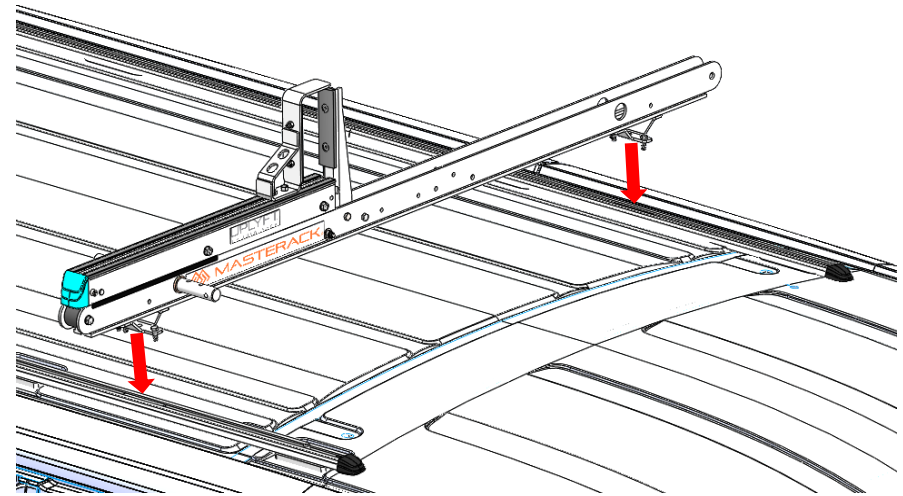

Step 16.

Lay front crossbow across mounting rails

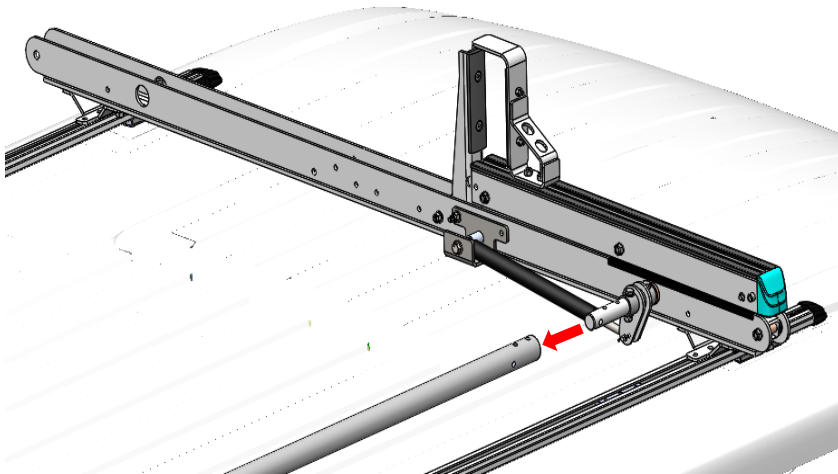

Step 17.

Set the front crossbow in place and slide into the connecting tube

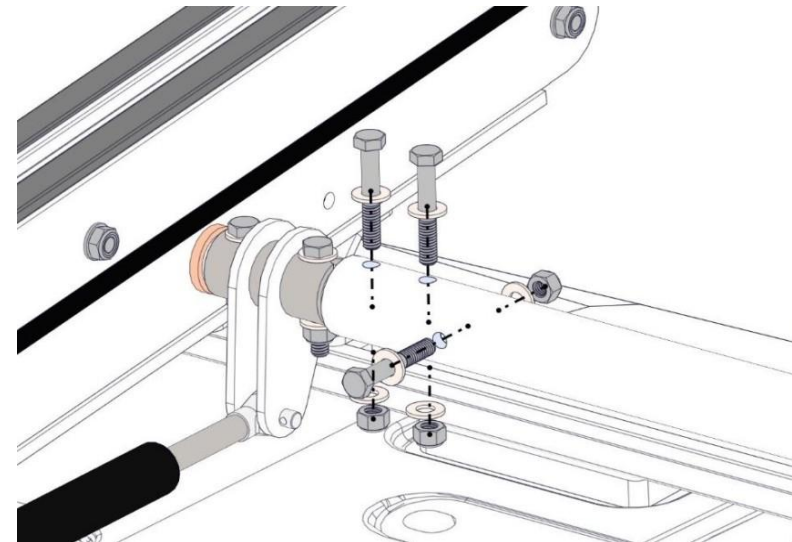

Step 18.

Install connecting tube with 5/16 X 2-1/2 bolts (3), washers (6), nuts (3) and
apply anti-seize to bolts

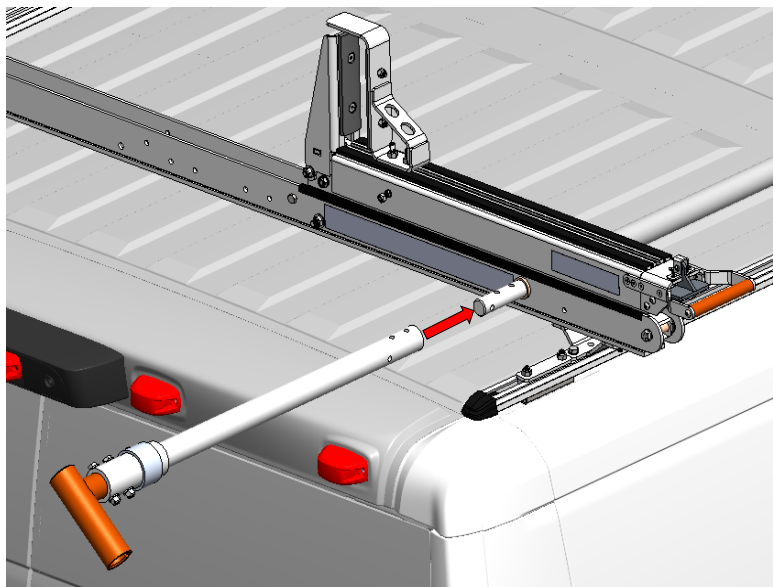

Step 19.
Install and tighten the handle assembly Using a 1/2" wrench and 1/2" impact wrench, 5/16" x 2" bolts with the 5/16" washers and 5/16" lock nuts 02P168.

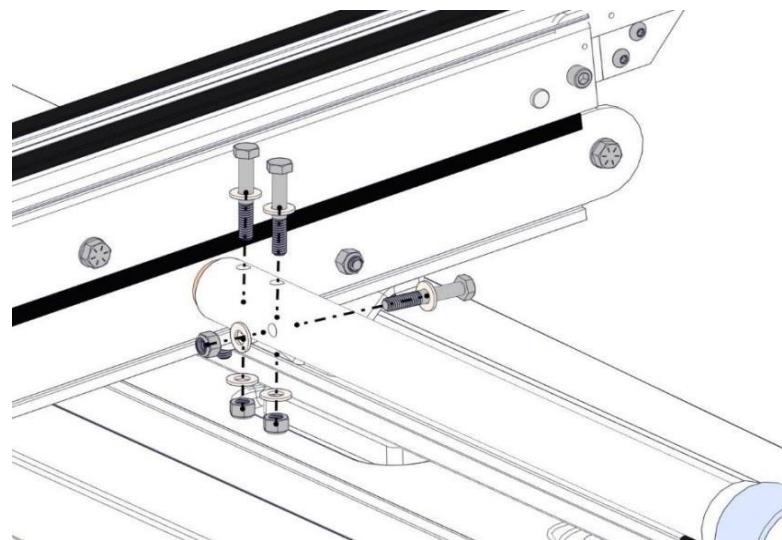

Step 20.
Fasten handles with 5/16 X 2-1/2 bolts (3), washers (6), nuts (3) and apply anti seize to bolts.

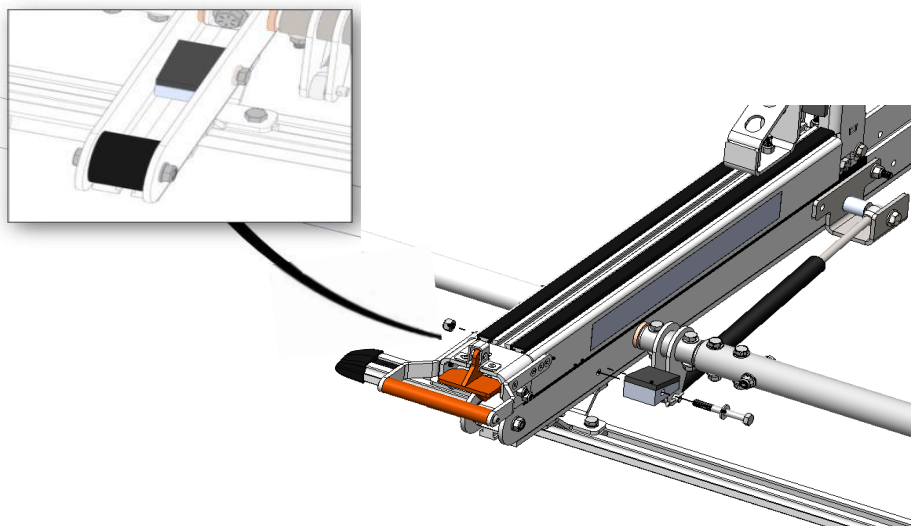

Step 21.
Install ladder stops (2) on curbside crossbows using 5/16" x 2-1/2" bolts, washer, bumper stop and nut and tighten with a 1/2" wrench

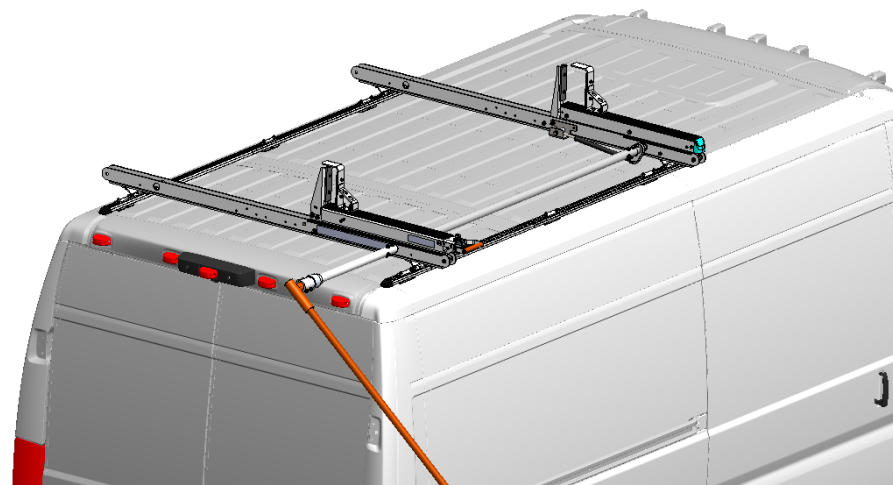

Step 22.
Assembly after installation