

## Recommended Tools

Air or Hand Ratchet



1/2" Socket



1/2" Combo Wrench



7/16" Combo Wrench



6mm Hex Allen Wrench



PN	DESCRIPTION	QTY
02P675	CROSSBOW ASSY – REAR	1
02P676	CROSSBOW ASSY - FRONT	1
02P665	ROTATION ASSEMBLY MR	1
02P328	CONNECTING TUBE - PWDR UPLYFT	1
02P103	DROP DOWN ASSEMBLY UPLYFT	1
02P663	LADDER STOP ASSY FRONT UPLYFT	1
02P664	LADDER STOP ASSY REAR UPLYFT	1
02P677	HARDWARE BAG UPLYFT SINGLE	1
02P393	MIDROOF HANDLE ASSY UPLYFT	1
02R245	MOUNTING RAIL	4
02P148	RAIL CAP UPLYFT	4
RM518016	SCREW PPHSM 14 X.625	4
02P791	HARDWARE BAG PROMASTER	1
02R247	SHIP PACK PROMASTER EXL	1



**UPLYFT™ LADDER RACK SYSTEM**

**Before installation, review this document to ensure that all parts and hardware are included in the package.**

In the event that parts are missing, please contact Masterack at 1-800-222-8785 to re-order missing parts.

**BEFORE INSTALLATION PLEASE REVIEW THIS ENTIRE DOCUMENT, UNTIL YOU ARE COMPLETELY FAMILIAR WITH ALL STEPS BEFORE BEGINNING. A "PRACTICE RUN" OF THESE STEPS/PROCEDURES MAY BE HELPFUL TO ASSIST YOU IN FAMILIARIZING YOURSELF THOROUGHLY AND AVOID COSTLY ERRORS.**

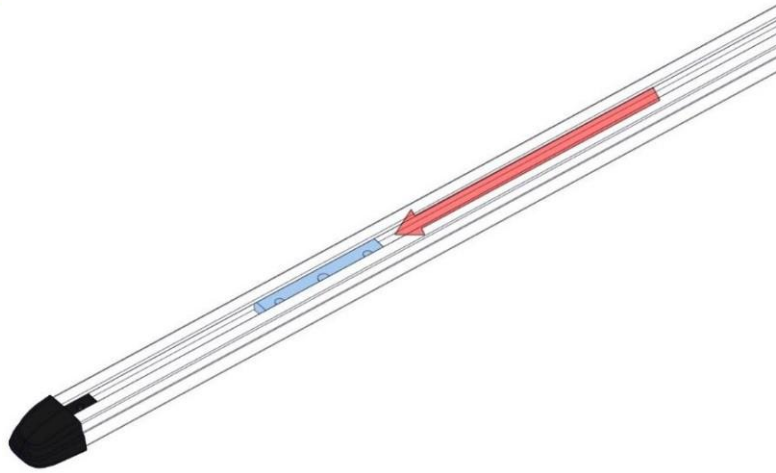

**Step 1.**

Slide receiver block (02P118) into both mounting rails (02R245)

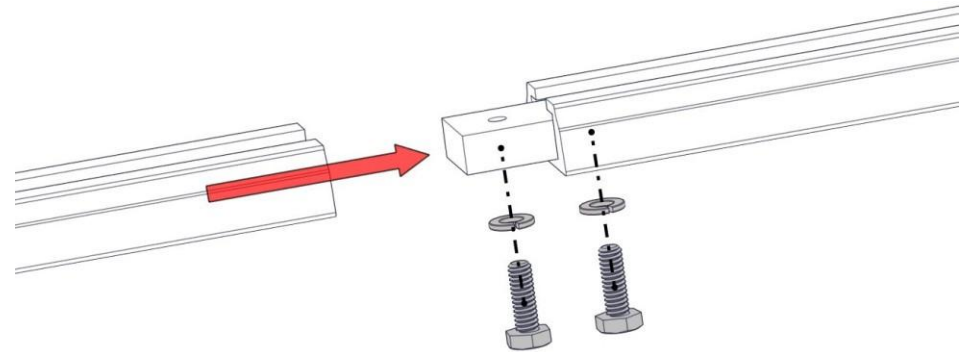

**Step 2.**

Slide joining block (02P125) into channels. Fasten with 1/4" lock washers and 1/4" X 1" hex bolts. Tighten with 7/16" wrench.

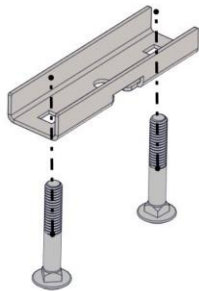

**Step 3.**

Install 2 of the 5/16" x 2" bolts into base bracket (repeat 8 times).

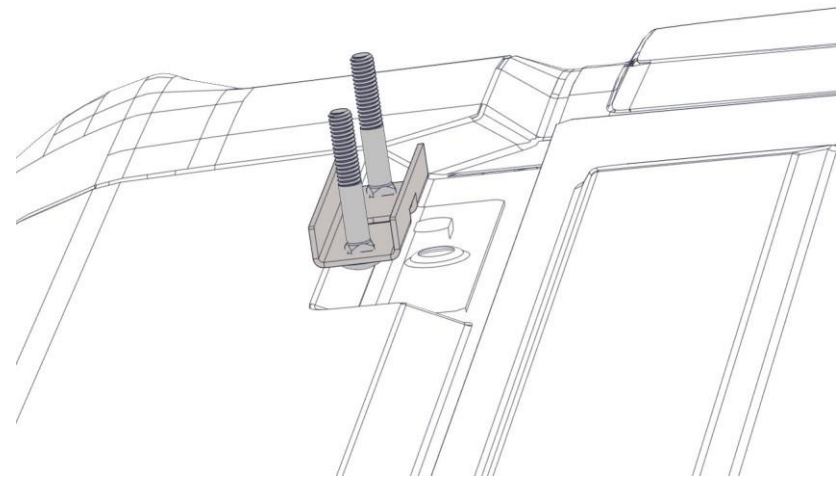

**Step 4.**

Install base brackets on vehicle by locating mounting tabs on top of vehicle. Pull tabs up and slide the bracket underneath. Repeat for all 6 locations.

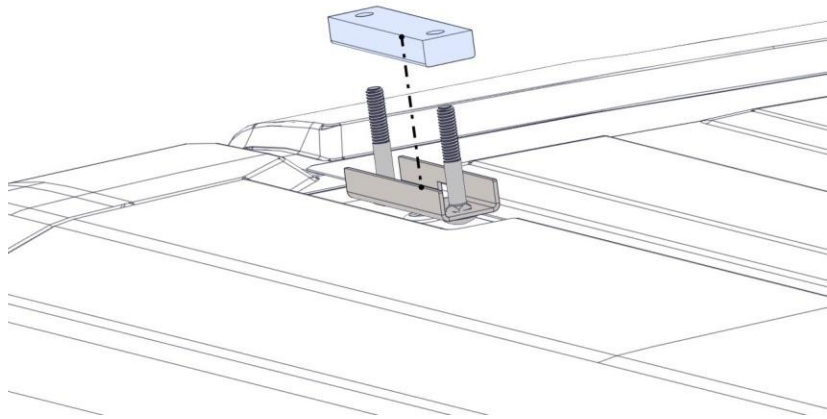

**Step 5.**  
Install spacer inside base brackets. Repeat for all 8 locations.

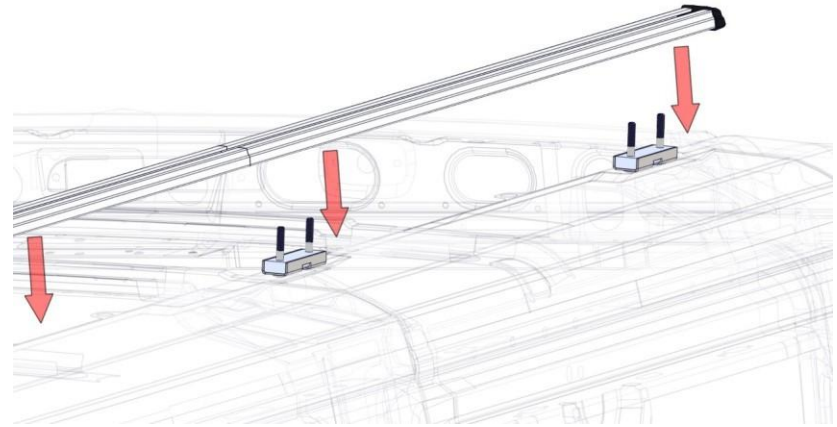

**Step 6.**  
Place rails on top of vehicle and slide receiver blocks from Step 1 all the way forward.



**Step 7.1**  
Starting at the rear of the vehicle, use the first hole as shown.

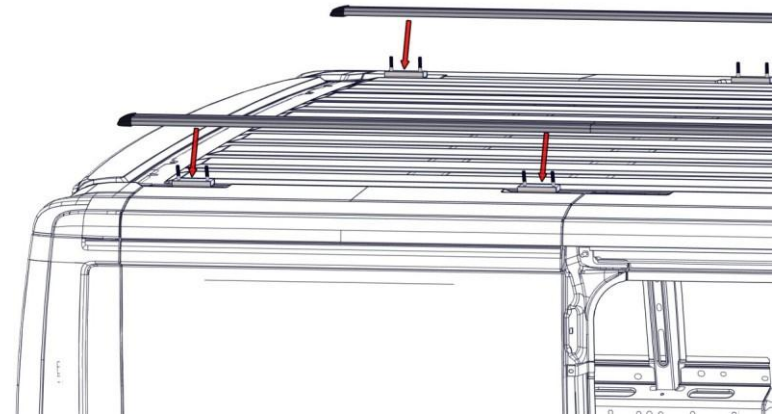

**Step 7.2**  
Place the rail on top of the base brackets.

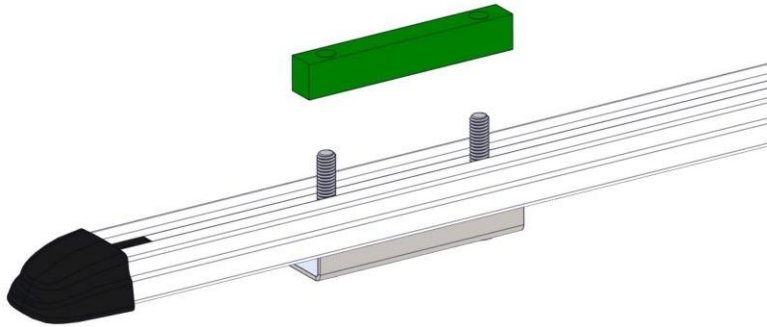

**Step 8.**

Install bolt spacers as shown over the bolts inside the channel.



**Step 9.**

Slide ladders stop (02P663) inside drop down and tighten with 9/16 socket or wrench.

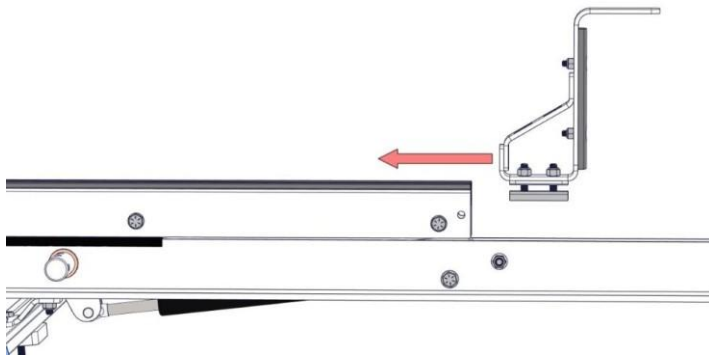

**Step 10.**

Slide ladders stop (02P664) tighten bolts using 9/16 socket or wrench.

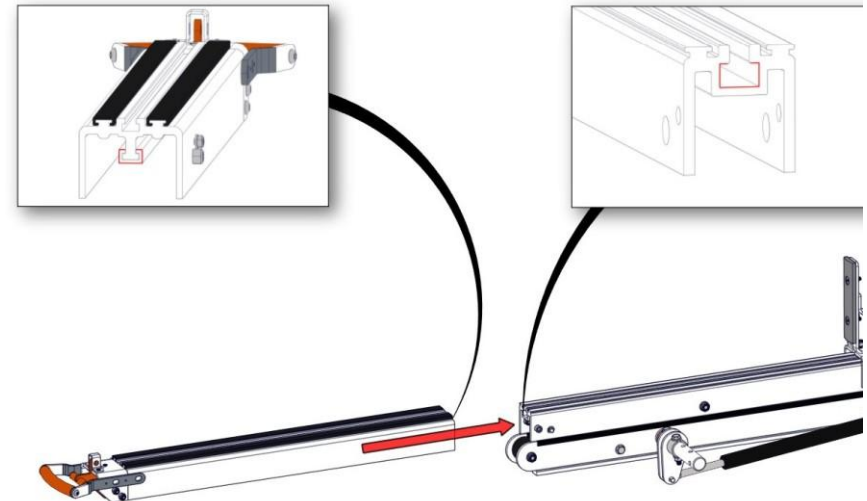

**Step 11.**

Slide the drop-down assembly into a crossbow by lining up the extrusion, and slide in.

## IMPORTANT TO NOTE:

A BLUE sticker indicates the FRONT Crossbows (02P676)



A GREEN sticker indicates the REAR Crossbows (02P675)

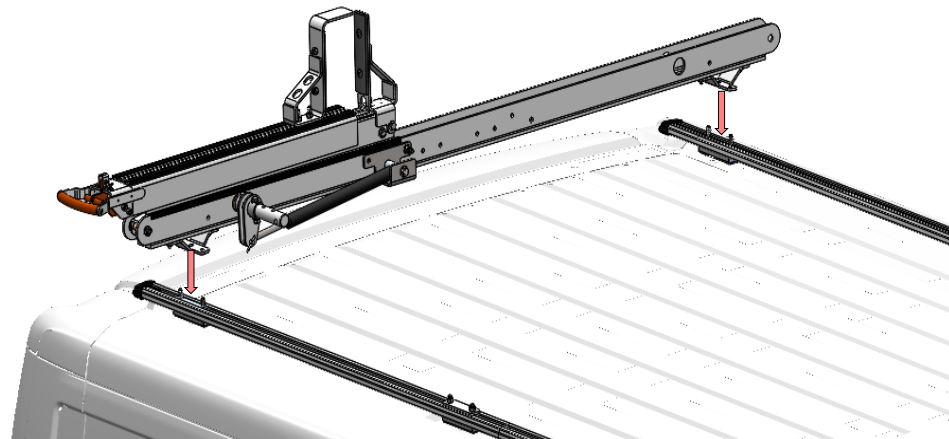

### **Step 12.**

Lay rear crossbow across mounting rails

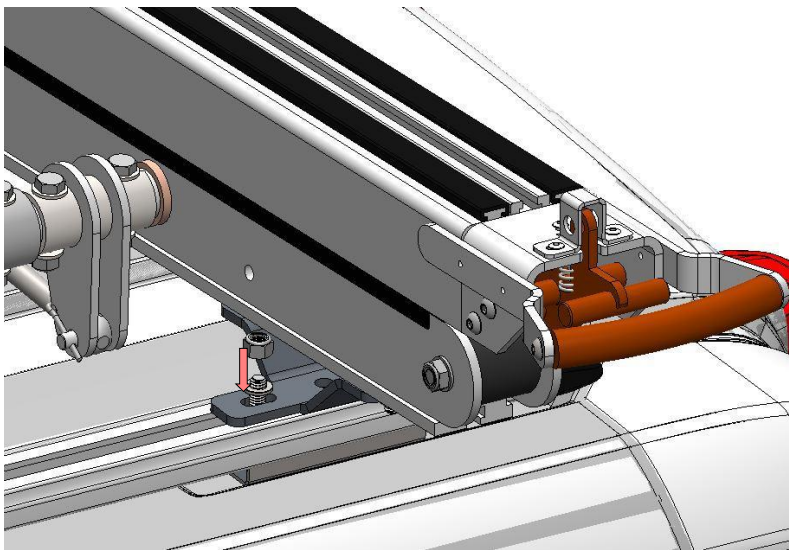

### **Step 13.**

Install 5/16 SS nuts 02P168 (4) onto bolts as shown above. apply anti-seize to bolts; **DO NOT TIGHTEN**

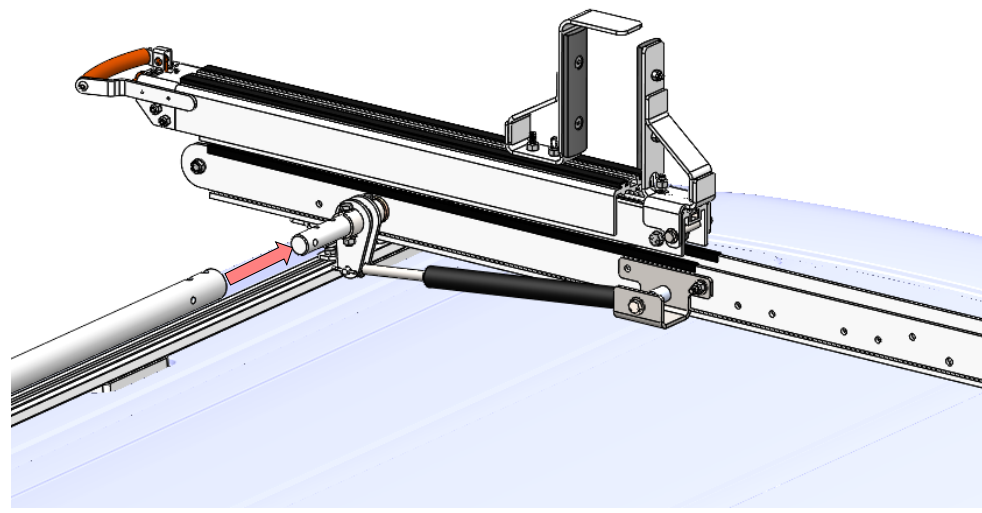

### **Step 14.**

Install the connecting tube 02P328 into the rear crossbow assembly.

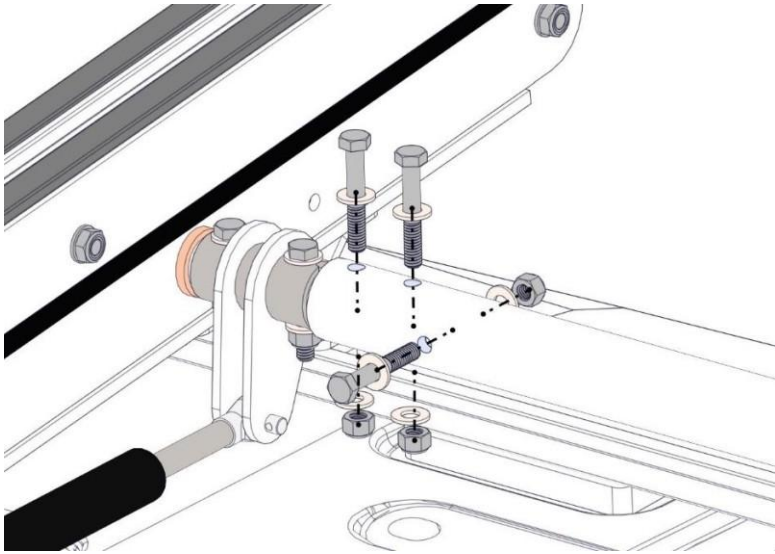

**Step 15.**

Install connecting tubes with 5/16 X 2-1/2 fasteners (3) & washers (6).  
apply anti-seize to bolts

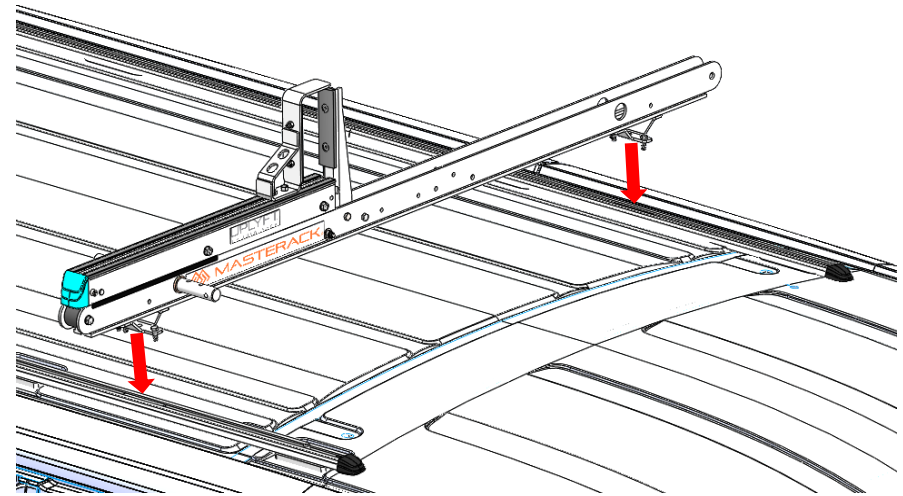

**Step 16.**

Lay front crossbow across mounting rails

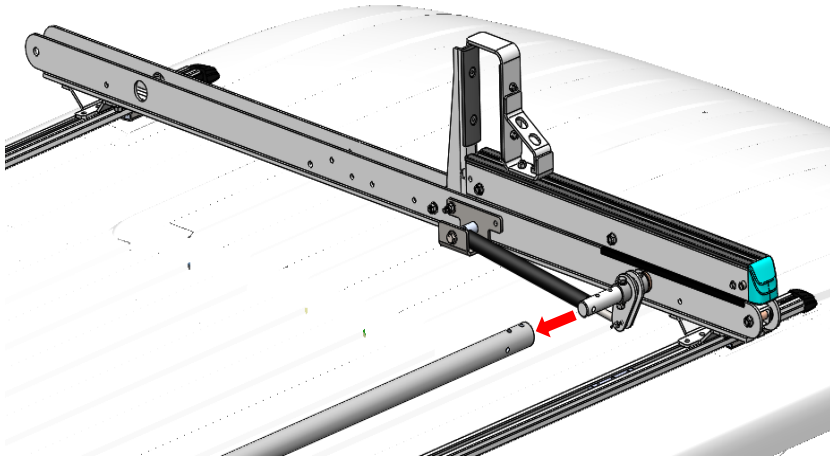

**Step 17.**

Set the front crossbow in place and slide into the connecting tube

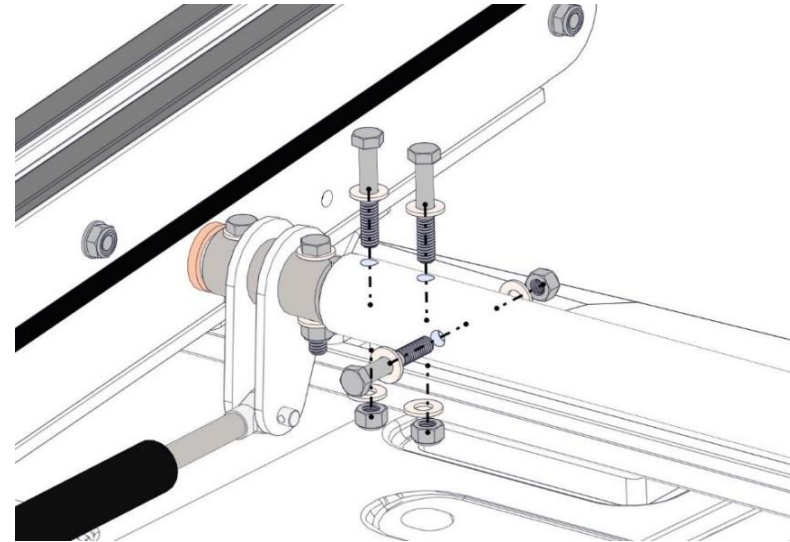

**Step 18.**

Install connecting tubes with 5/16 X 2-1/2 fasteners (3) & washers (6).  
apply anti-seize to bolts



**Step 19.**  
Install and tighten the handle assembly Using a 1/2" wrench and 1/2" impact wrench, 5/16" x 2" bolts with the 5/16" washers and 5/16" lock nuts 02P168.

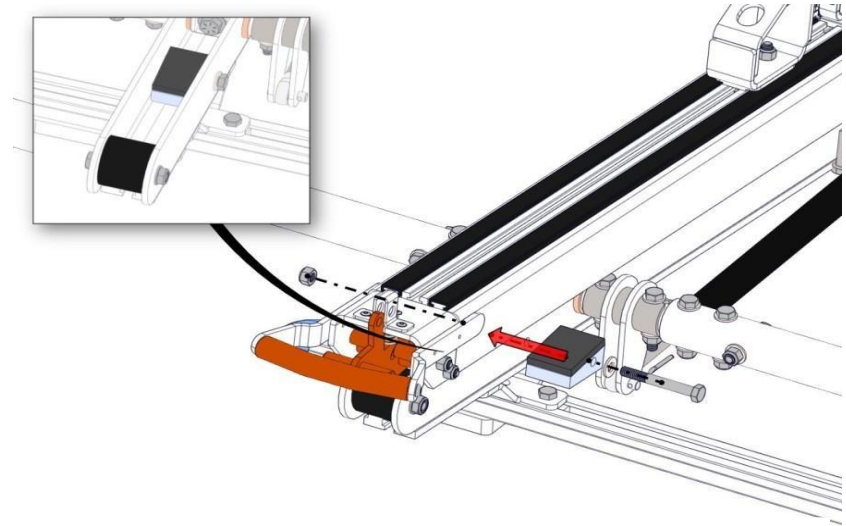

**Step 20.**  
Install ladder stops (2) on curbside crossbows using 5/16" x 2-1/2" bolts, washer, bumper stop and nut and tighten with a 1/2" wrench

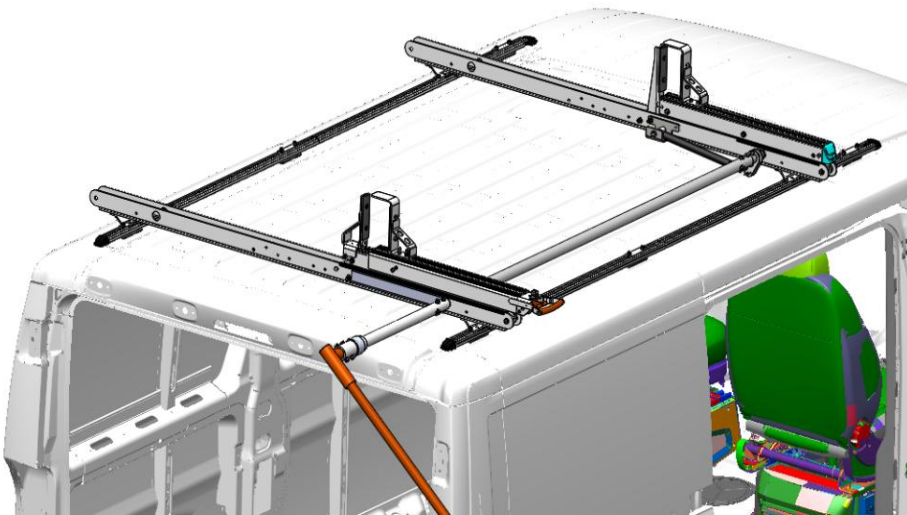

**Step 21.**  
Assembly after installation