

Recommended Tools

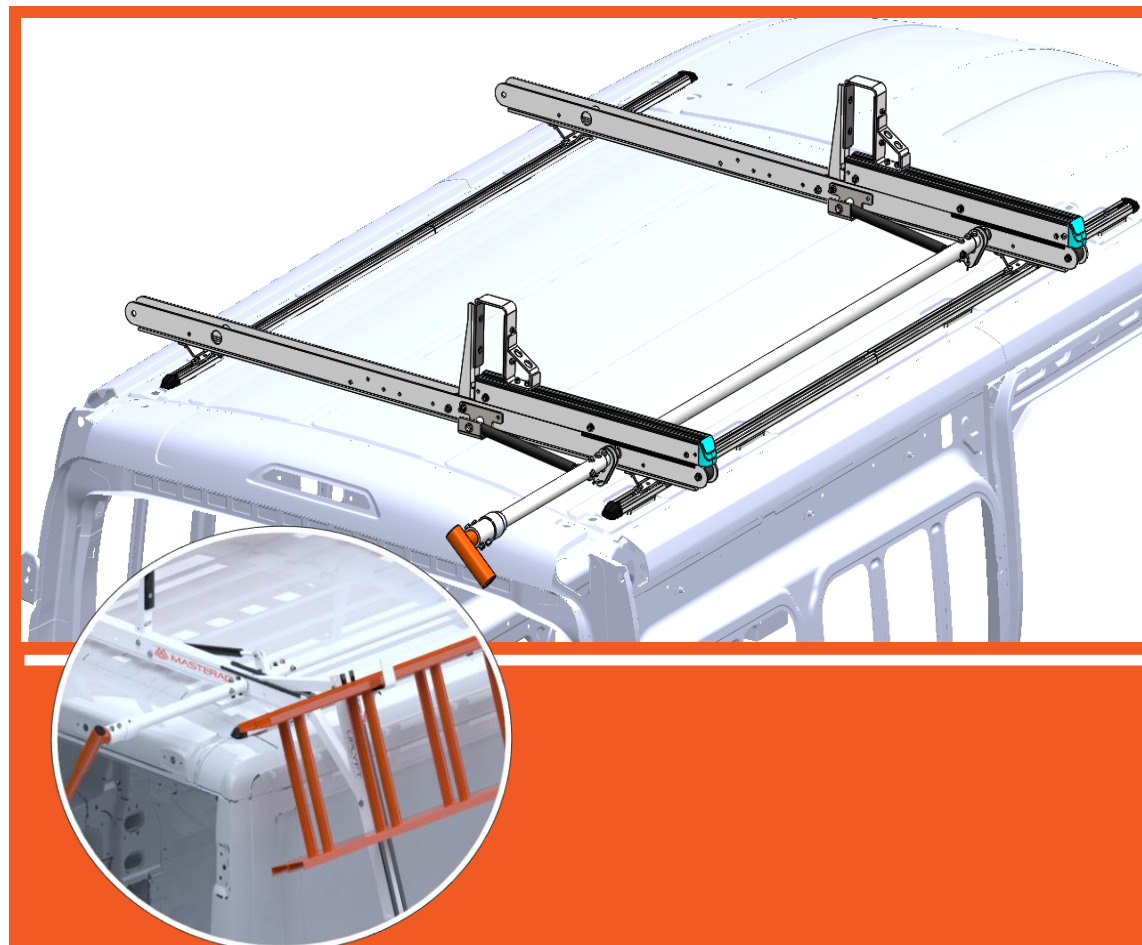
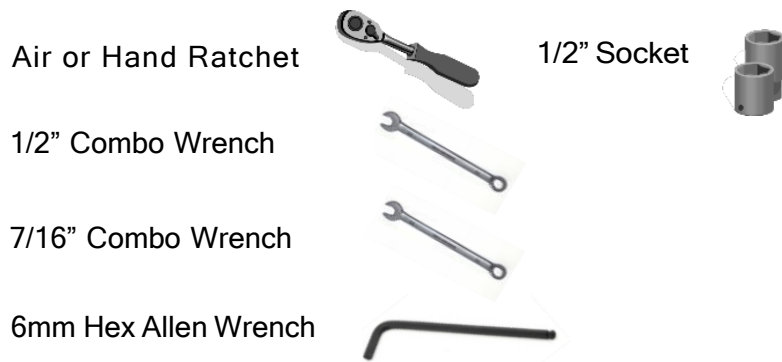

PN	DESCRIPTION	QTY
02P675	CROSSBOW ASSY – REAR	2
02P665	ROTATION ASSEMBLY MR	1
02P328	CONNECTING TUBE - PWDR UPLYFT	1
02P803	HANDLE ASSEMBLY LR	1
02P677	HARDWARE BAG UPLYFT SINGLE	1
02P112	MOUNTING RAIL	4
02P148	RAIL CAP UPLYFT	4
RM518016	SCREW PPHSM 14 X.625	4
02P673	HARDWARE BAG UPLYFT TRANSIT	1
02P756	UPLYFT TRANSIT SHIP PACK	1

UPLYFT™ LADDER RACK SYSTEM

Before installation, review this document to ensure that all parts and hardware are included in the package.
In the event that parts are missing, please contact Masterack at 1-800-222-8785 to re-order missing parts.

BEFORE INSTALLATION, PLEASE REVIEW THIS ENTIRE DOCUMENT, UNTIL YOU ARE COMPLETELY FAMILIAR WITH ALL STEPS BEFORE BEGINNING. A "PRACTICE RUN" OF THESE STEPS/PROCEDURES MAY BE HELPFUL TO ASSIST YOU IN FAMILIARIZING YOURSELF THOROUGHLY AND AVOID COSTLY ERRORS.

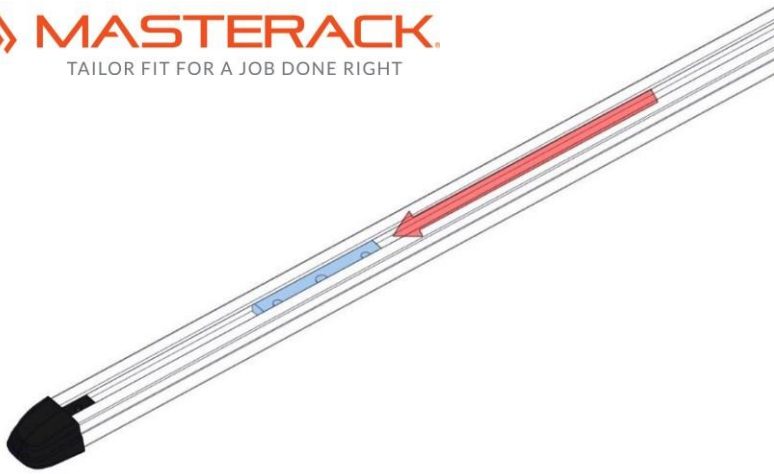

Step 1

Slide receiver block (02P118) into each of the 4 mounting rails (02P112)

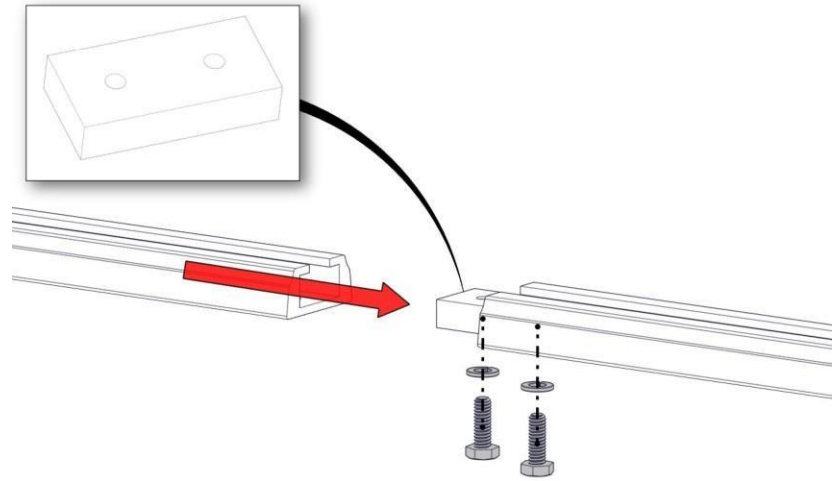

Step 2.

Slide joining block (02P125) into channels. Fasten with 1/4" lock washers and 1/4" X 1" hexbolts. Tighten with 7/16" wrench

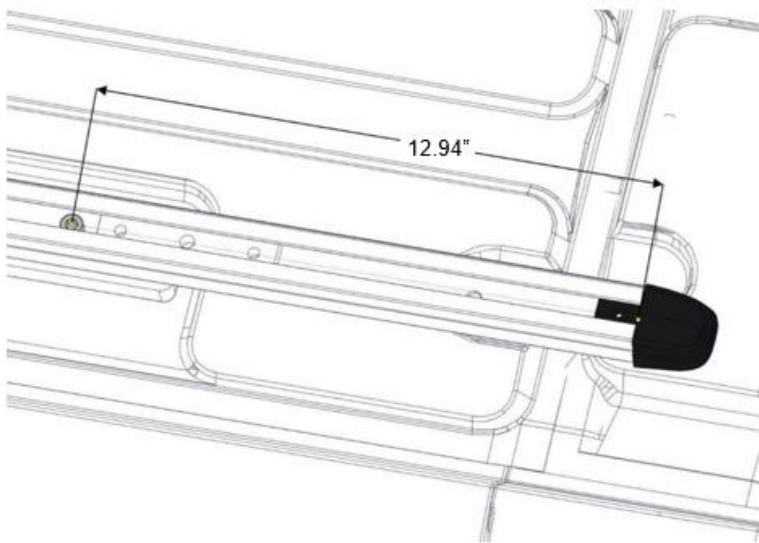

Step 3. (130" Wheelbase)

Starting with the rear bolt, use the 2nd hole from the end, Located approx. 13" from the end.

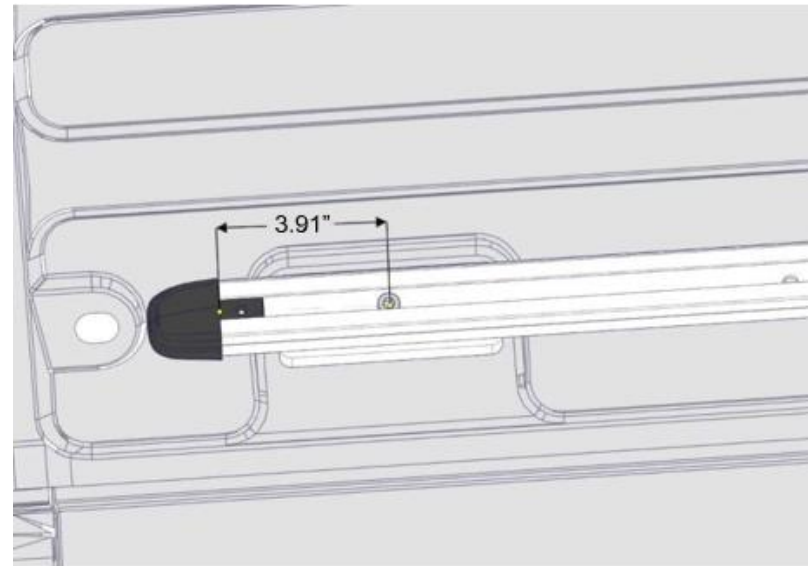

Step 3. (148" Wheelbase)

Starting with the rear bolt, use the 1st hole from the end, located approx. 4" from the end.

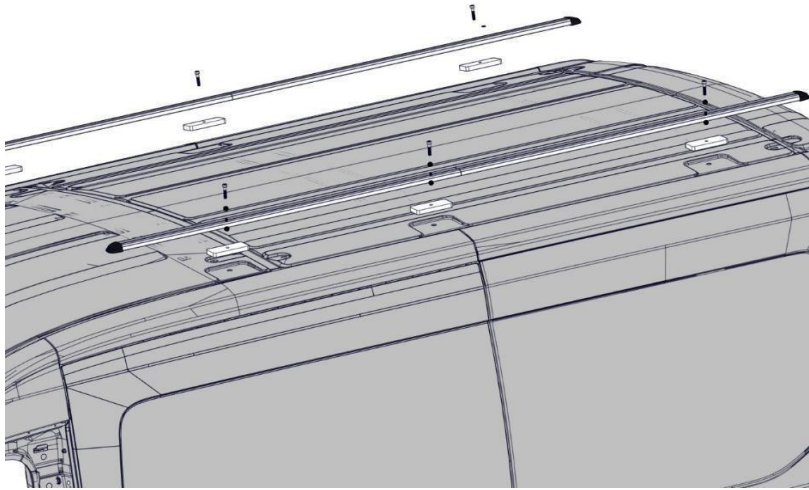

Step 4.
Fasten rails using 8 X 40MM socket cap screws (02P332) with nylon spacers (02P135) in between rail. Use the 6mm Allen wrench to tighten bolts.

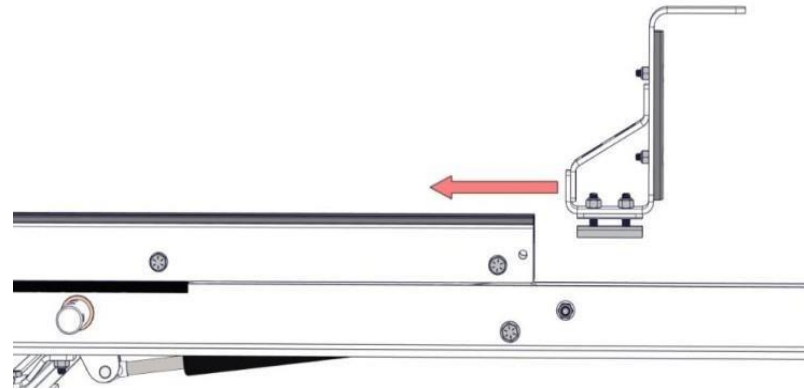

Step 5.
Slide ladder stop (02P664) tighten bolts using 9/16 socket or wrench.

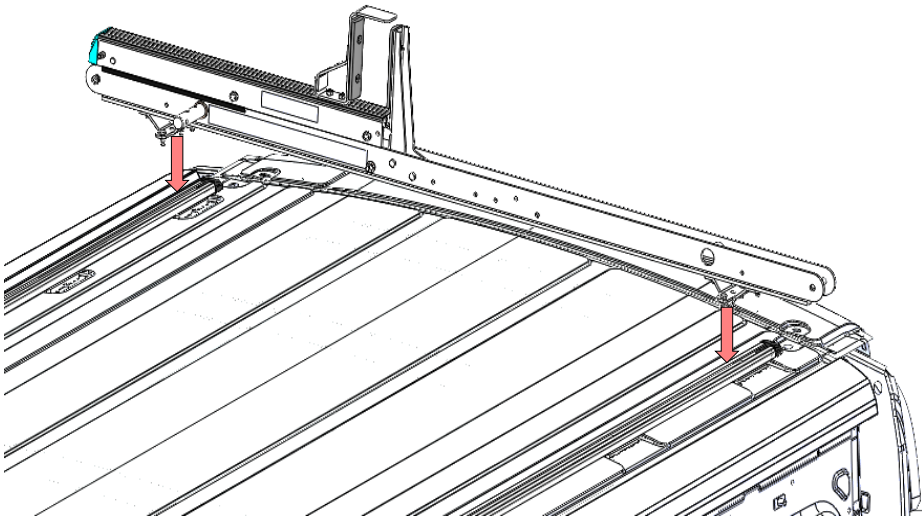

Step 6.
Lay rear crossbow across mounting rails.

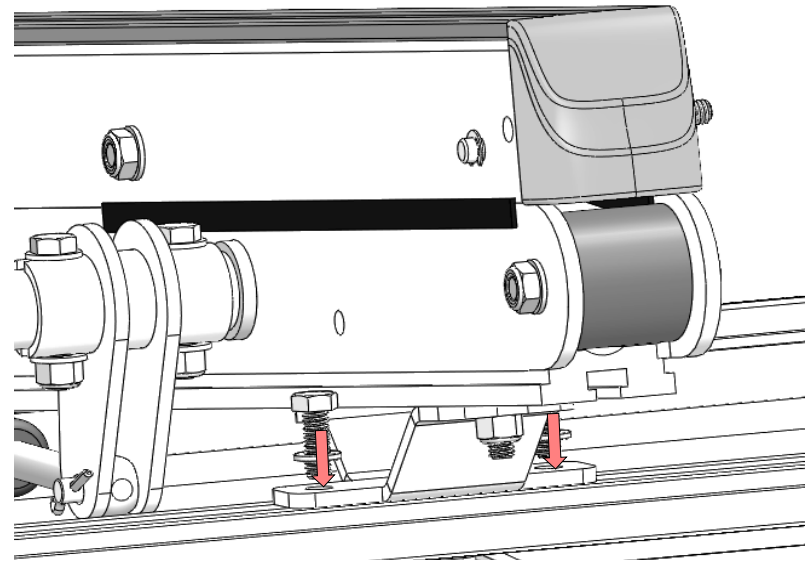

Step 7.
Install 5/16 X 7/8 bolts (4) with lock washers (4) through crossbow mounts into receiver blocks and apply seize to bolts. **Do not tighten**

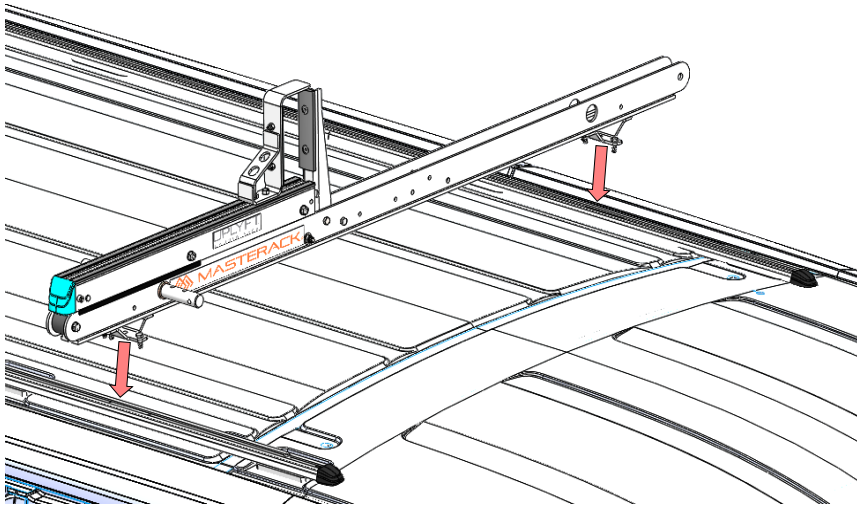

Step 8.

Lay front crossbow across mounting rails

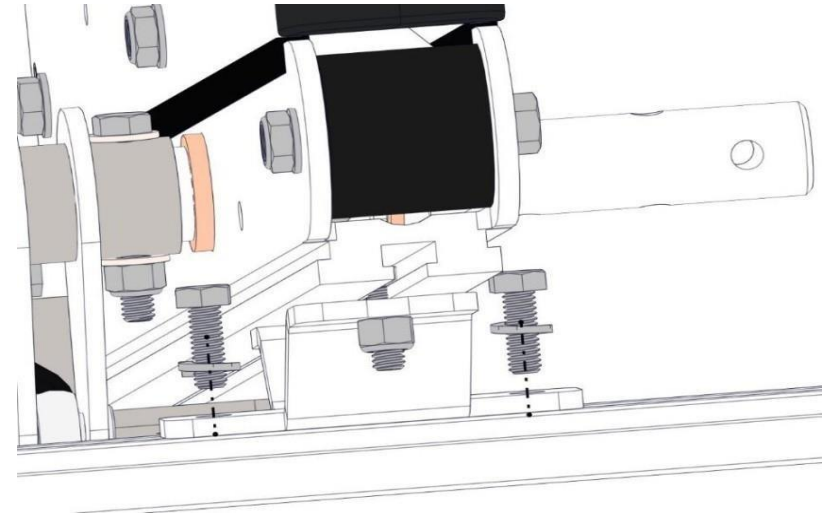

Step 9.

Install 5/16 X 7/8 bolts (4) with lock washers (4) through crossbow mounts into receiver blocks and apply seize to bolts Do not tighten

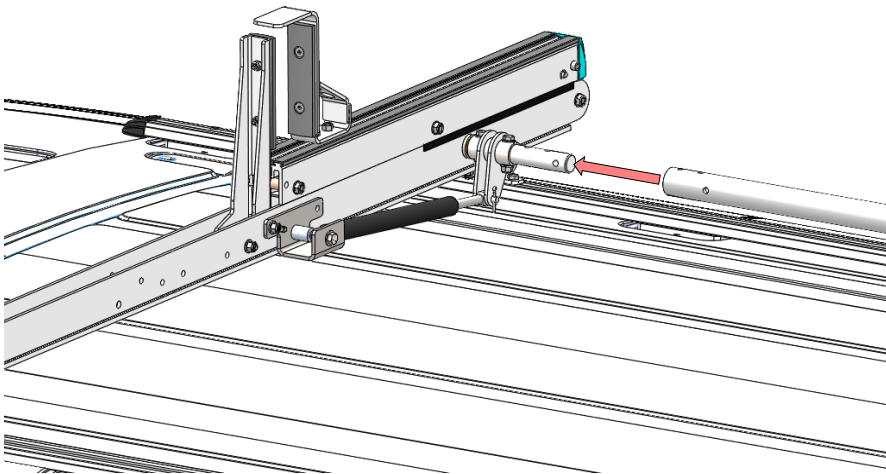

Step 10.

Slide Connecting tube (O2P328) into front crossbow.
Line holes up with crossbow rod and connecting tube

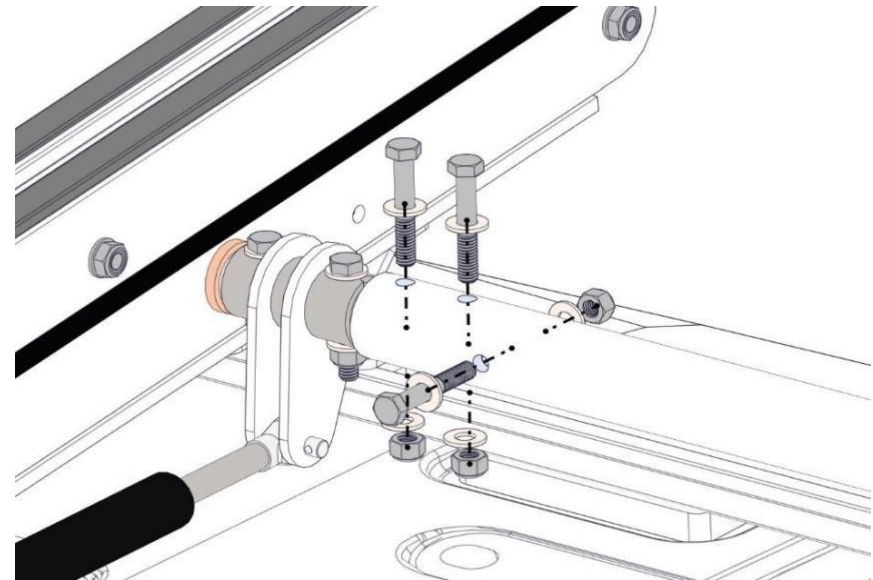

Step 11.

Install connecting tubes with 5/16" X 2 - 1/2"
fasteners (3) & washers (6) and apply seize to bolts

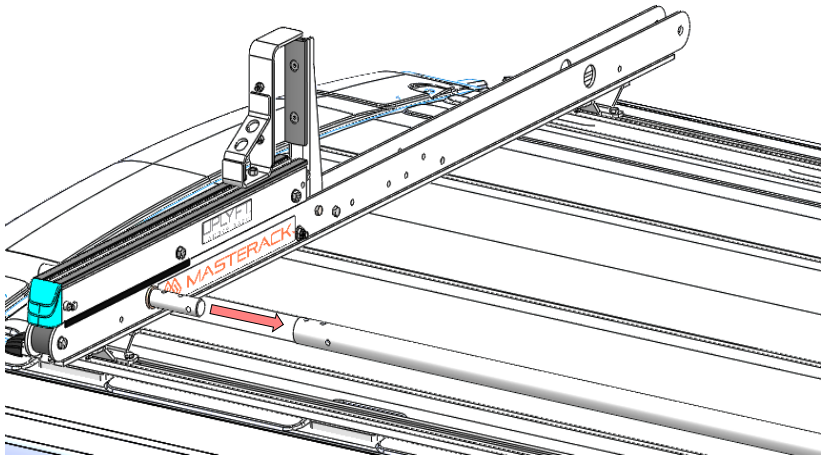

Step 12.

Slide rear crossbow into connecting tube

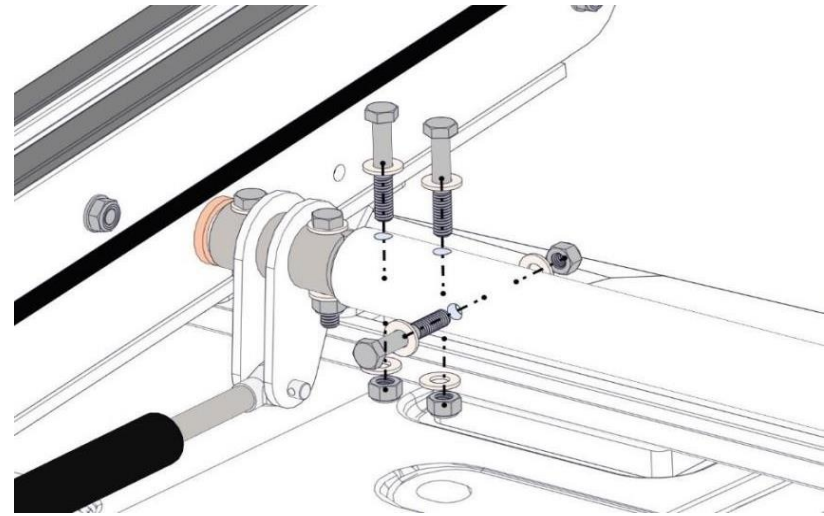

Step 13.

Install connecting tubes with 5/16" X 2 -1/2" fasteners (3) & washers (6) and apply seize to bolts

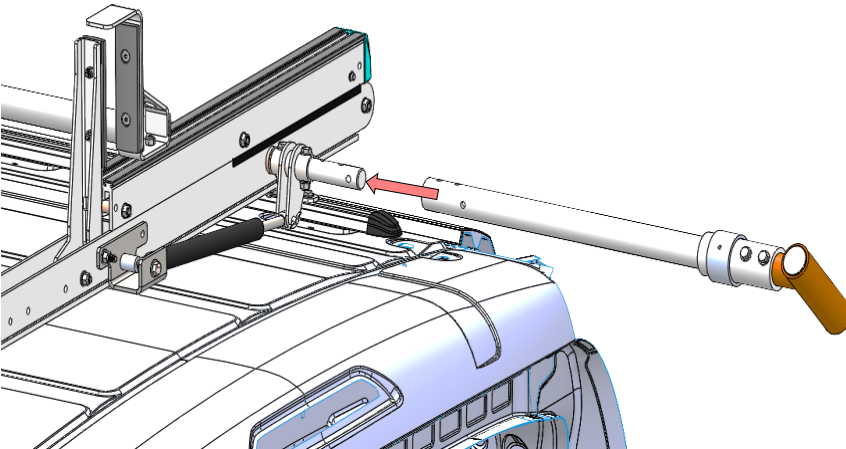

Step 14.

Install handle assembly into rear crossbow

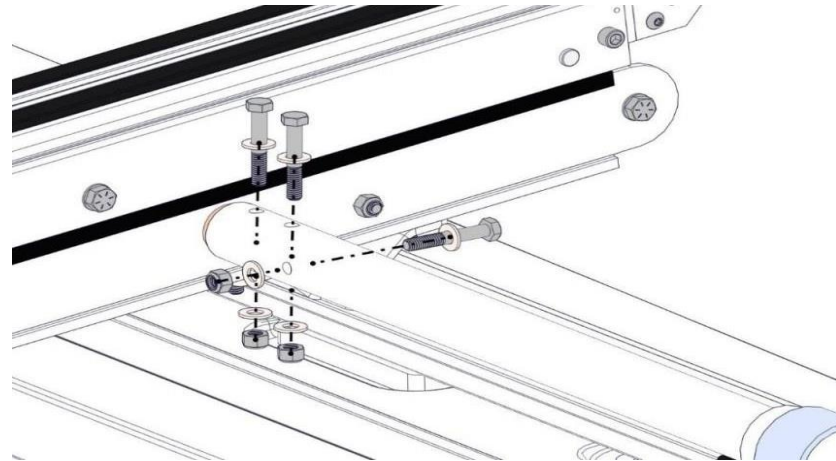

Step 15.

Fasten handle with 5/16 X 2-1/2 bolts (3) and washers (6) and apply seize to bolts

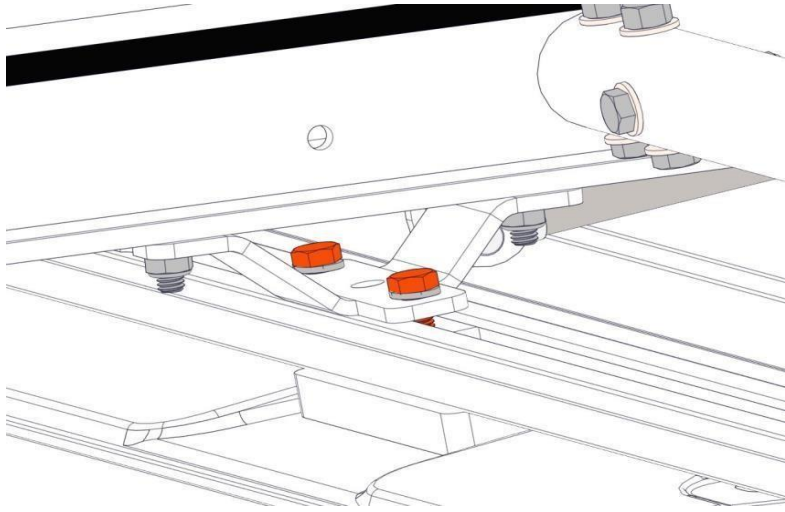

Step 16.
Tighten crossbow bolts

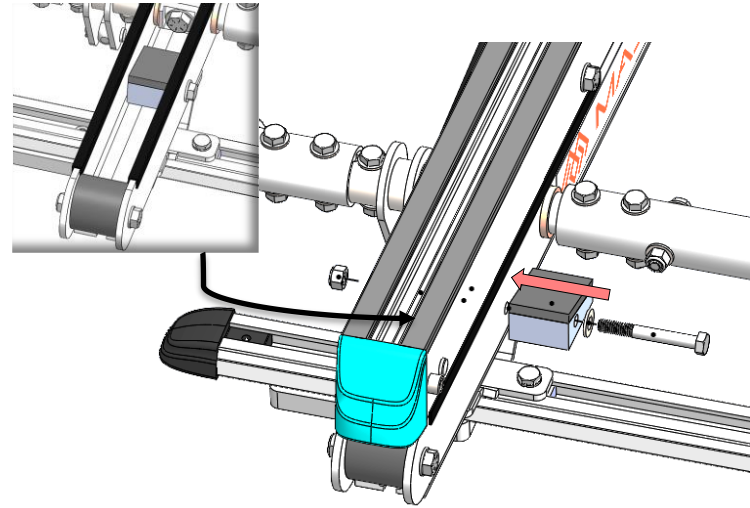

Step 17.
Install ladder stops (2) on curbside crossbows using 5/16" x 2-1/2" bolts, washer, bumper stop and nut and tighten with a 1/2" wrench