

FORD TRANSIT 3RD CROSSBOW LADDER RACK (02S909KP)

Recommended Tools

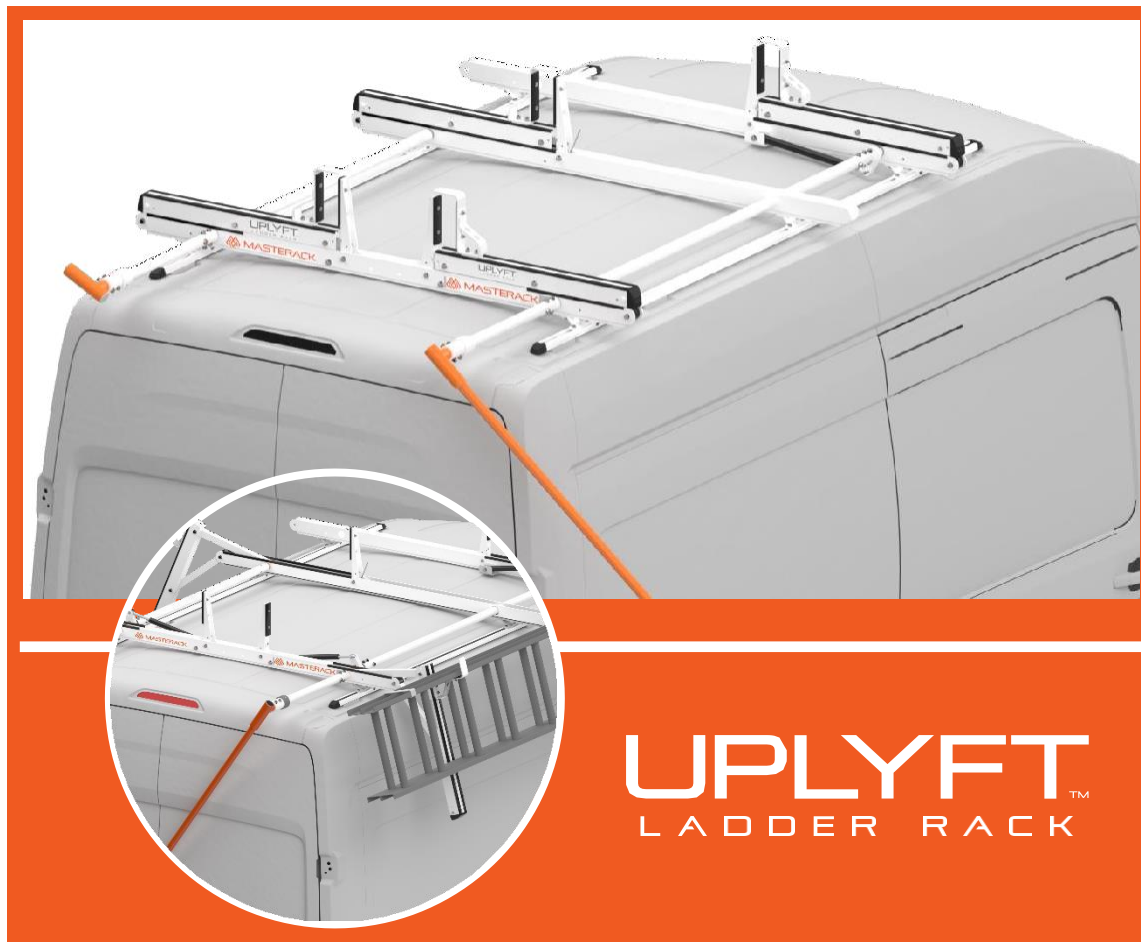
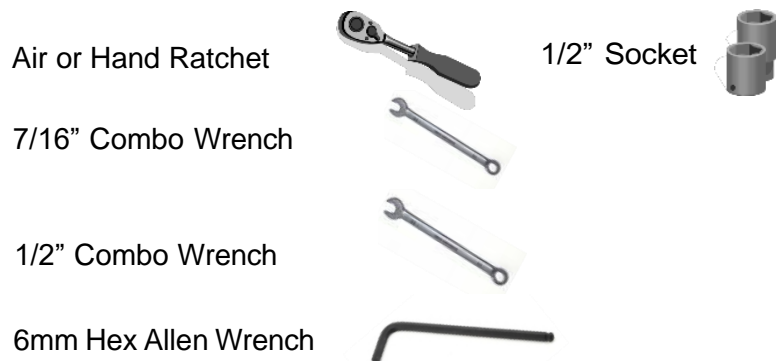

UPLYFT™
LADDER RACK

PN	DESCRIPTION	QTY
02P675	CROSSBOW ASSY – REAR	1
02P325	CROSSBEAM ASSEMBLY UPLYFT	1
02R122	CROSSBOW ASSY 3RD UPLYFT	1
02P328	CONNECTING TUBE - PWDR UPLYFT	1
02R038	CONNECTING TUBE 3RD CROSSBOW	1
02P803	HANDLE ASSEMBLY LR	1
02P663	LADDER STOP ASSY FRONT UPLYFT	2
02P664	LADDER STOP ASSY REAR UPLYFT	2
02P665	ROTATION ASSEMBLY MR UPLYFT	2
02P666	HARDWARE BAG UPLYFT	1
02P112	MOUNTING RAIL	4
02P148	RAIL CAP UPLYFT	4
RM518016	SCREW PPHSM 14 X.625	4
02R125	UPLYFT TRANSIT SHIP BAG 3RD	1
02R126	HARDWARE BAG UPLYFT TRANSIT 3R	1

UPLYFT™ LADDER RACK SYSTEM

Before installation, review this document to ensure that all parts and hardware are included in the package.
In the event that parts are missing, please contact Masterack at 1-800-222-8785 to re-order missing parts.

BEFORE INSTALLATION PLEASE REVIEW THIS ENTIRE DOCUMENT, UNTIL YOU ARE COMPLETELY FAMILIAR WITH ALL STEPS BEFORE BEGINNING. A “PRACTICE RUN” OF THESE STEPS/PROCEDURES MAY BE HELPFUL TO ASSIST YOU IN FAMILIARIZING YOURSELF THOROUGHLY AND AVOID COSTLY ERRORS.

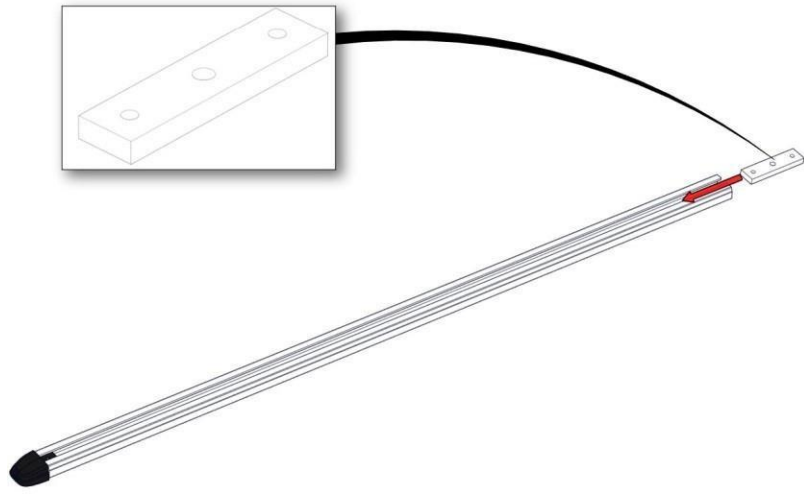

Step 1.
Slide receiver block (02P118) into each of the 4 mounting rails (02P112)

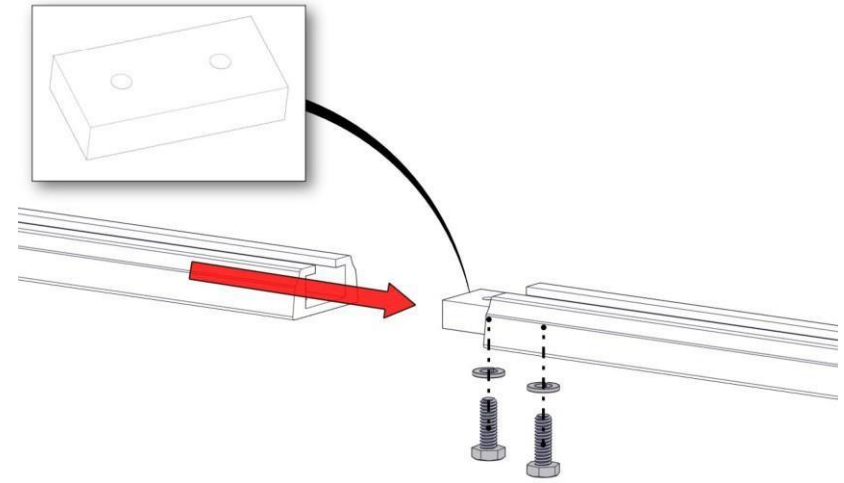

Step 2.
Slide joining block (02P125) into channels. Fasten with 1/4" lock washers and 1/4" X 1" hex bolts. Tighten with 7/16" wrench.

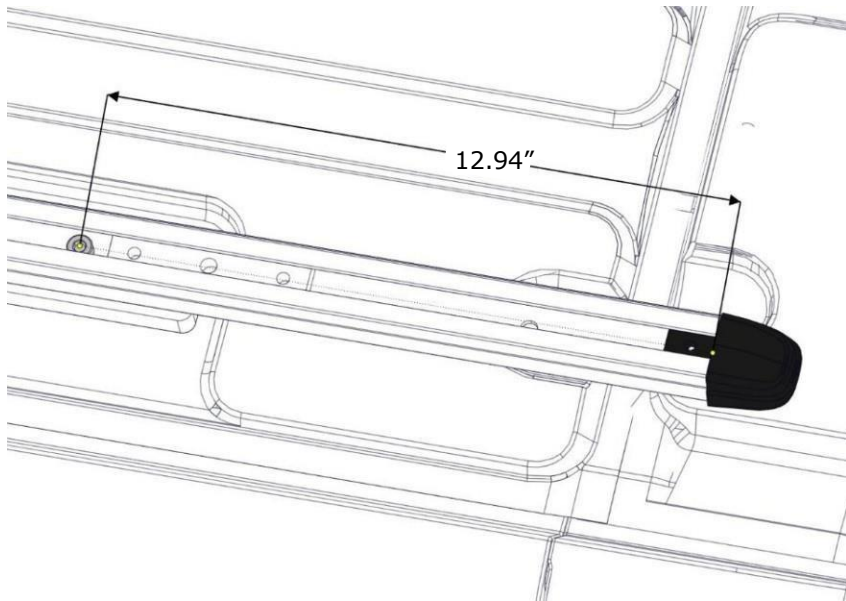

Step 3. (130" Wheelbase)
Starting with the rear bolt, use the 2nd hole from the end, Located approx. 13" from the end

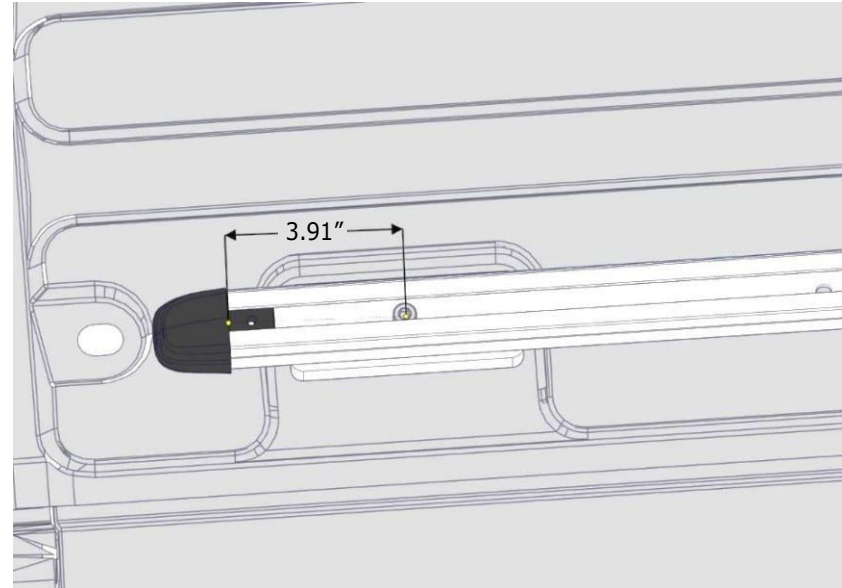

Step 3. (148" Wheelbase)
Starting with the rear bolt, use the 1st hole from the end, located approx. 4" from the end

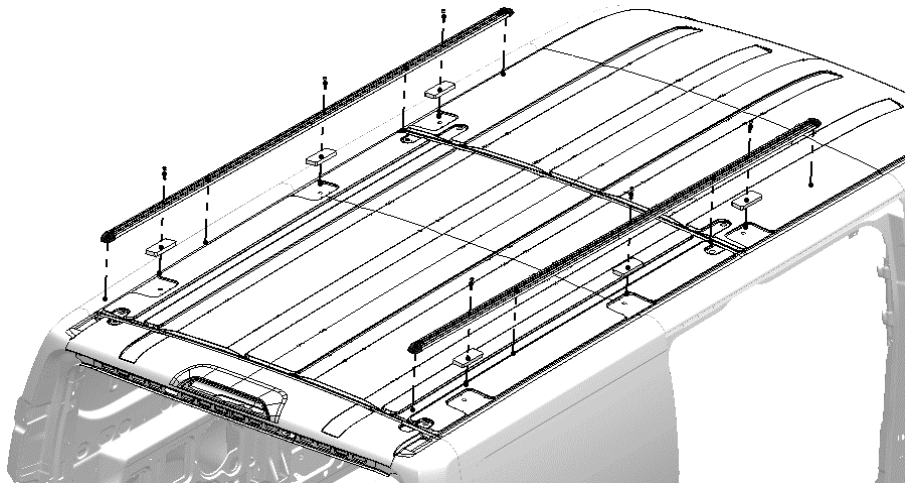

Step 4.

Fasten rails using 8 X 40MM socket cap screws (02P332) with nylon spacers (02P135) in between rails. Use the 6mm Allen wrench to tighten bolts.

IMPORTANT TO NOTE:

A BLUE sticker indicates the FRONT Crossbow (02P325)



A GREEN sticker indicates the REAR Crossbow (02P675)

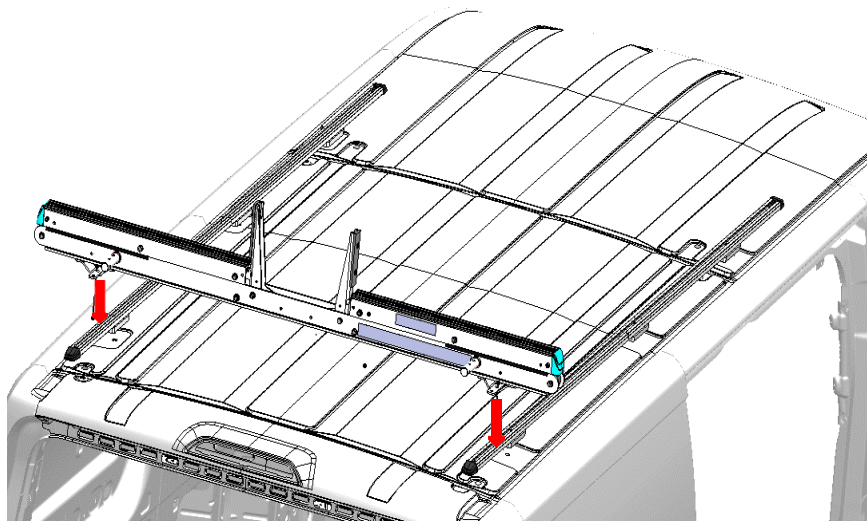

Step 5.

Lay rear crossbow across mounting rails

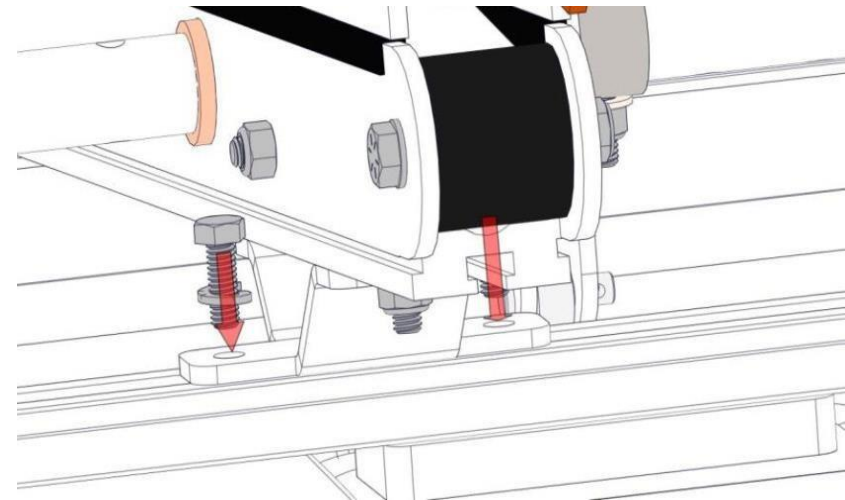

Step 6.

Install 5/16 X 7/8 bolts (4) with lock washers (4) through crossbow mounts into receiver blocks and apply seize to bolts Do not tighten

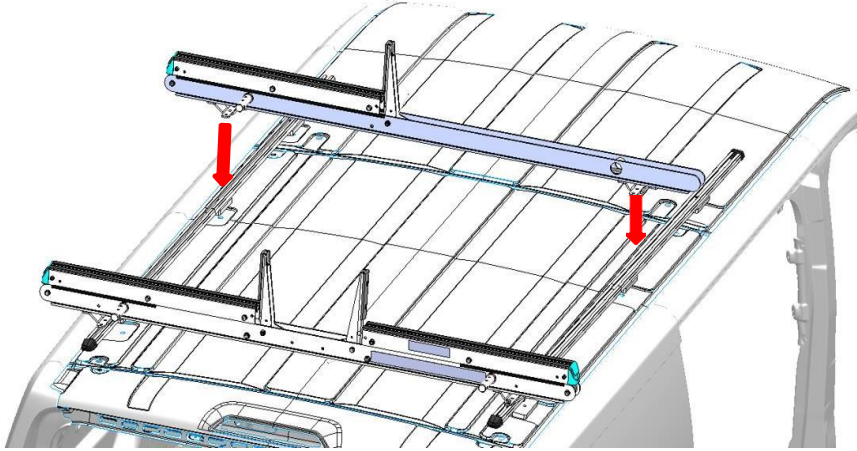

Step 7.
Lay middle crossbow across mounting rails

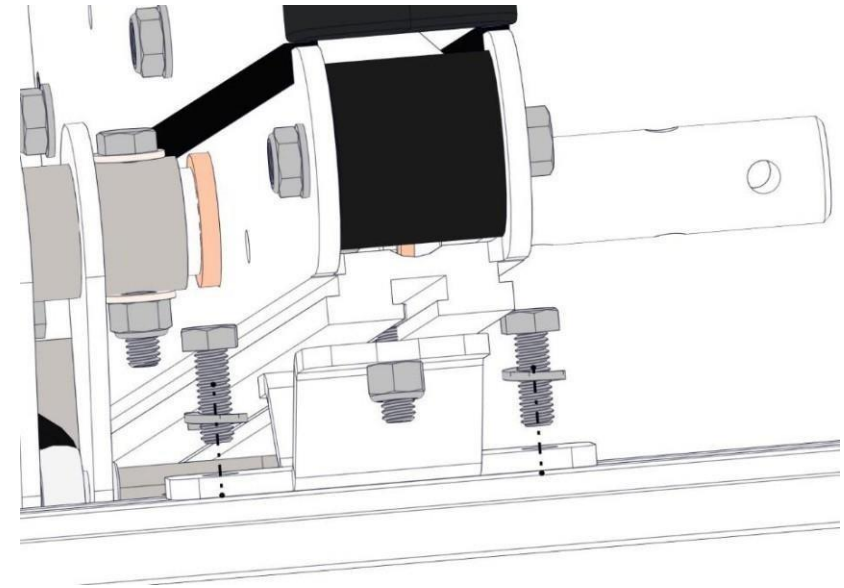

Step 8.
Install 5/16 X 7/8 bolts (4) with lock washers (4) through crossbow mounts into receiver blocks and apply seize to bolts **Do not tighten**

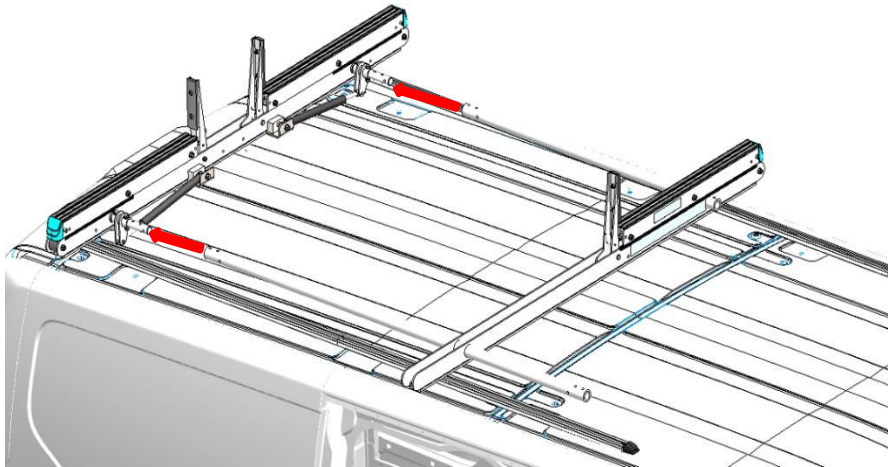

- Step 9.**
- Slide Connecting tubes (02P328) which move through center crossbow to rear crossbow.
 - Slide connecting tube (Short) between center and rear crossbow. Line holes up with crossbow rod and connecting tube

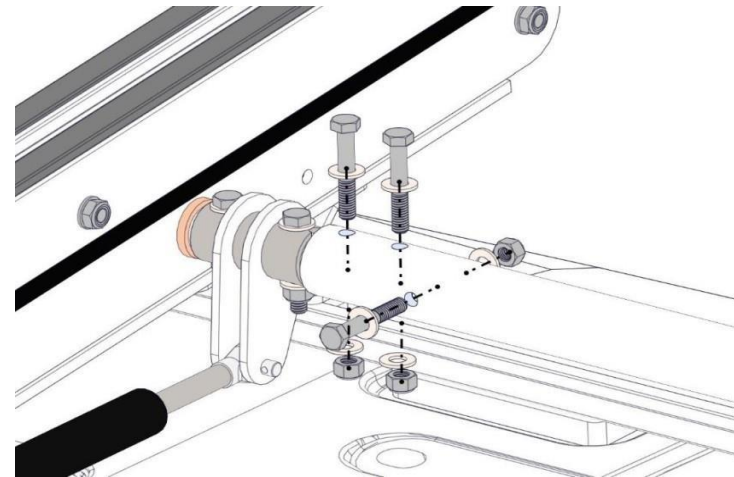

- Step 10.**
- Install connecting tubes with 5/16" X 2 - 1/2" fasteners (6) & washers (12) and apply seize to bolts

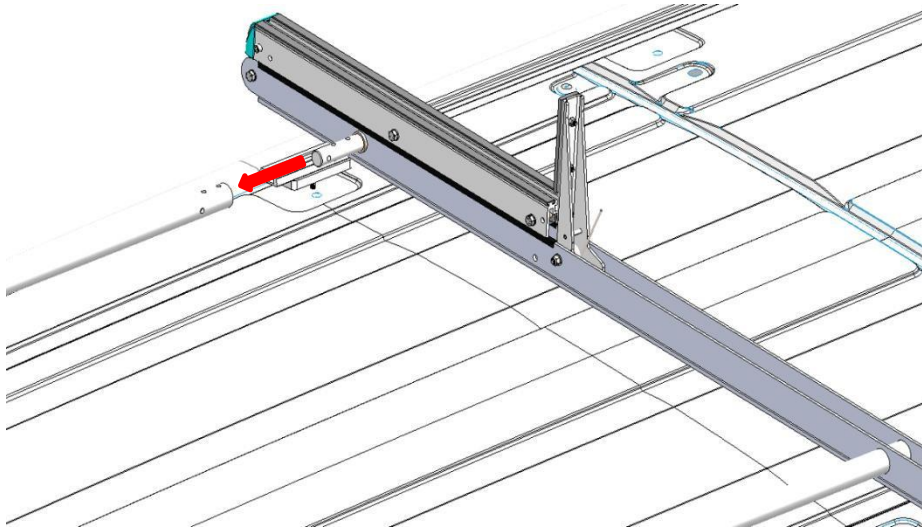

Step 11.
Slide middle crossbow into connecting tubes

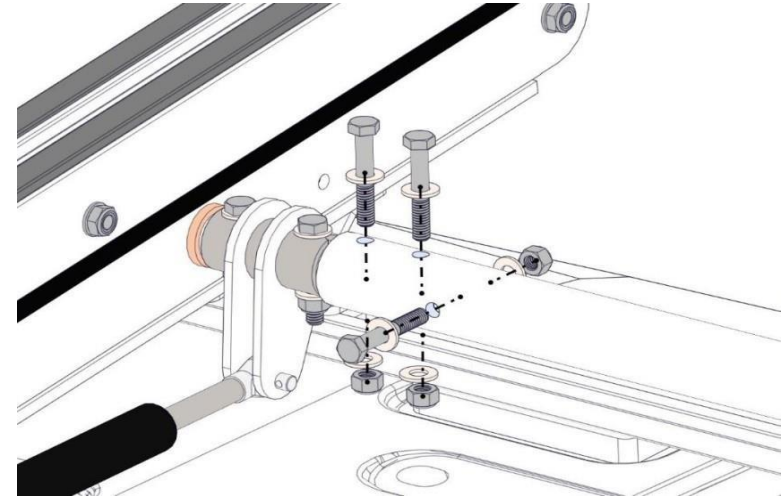

Step 12.
Install connecting tubes with 5/16" X 2 -1/2" fasteners (9) & washers (18) and apply seize to bolts

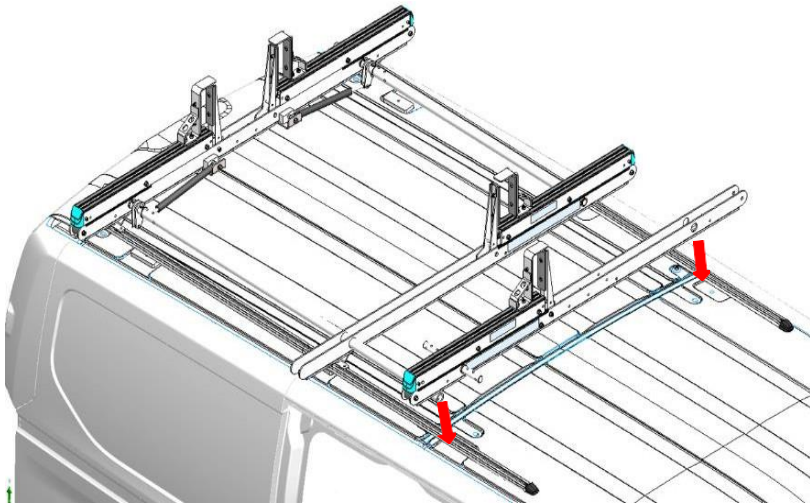

Step 13.
Lay front crossbow across mounting rails

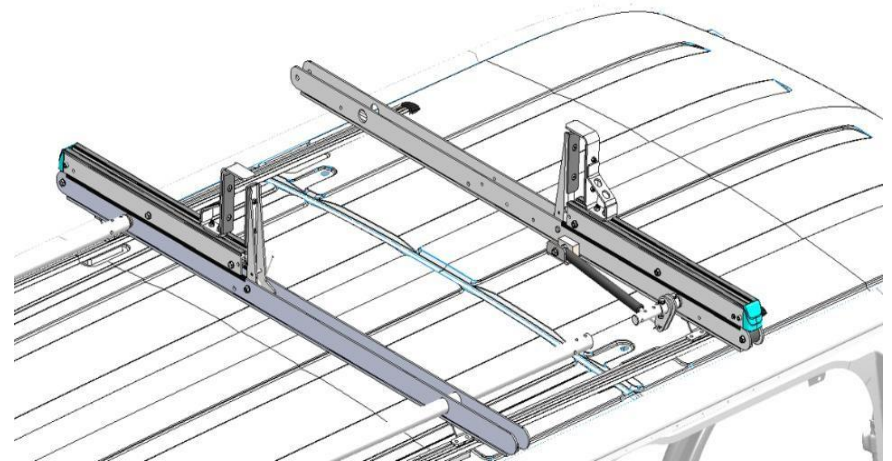

Step 14.
Slide front crossbow into connecting tubes

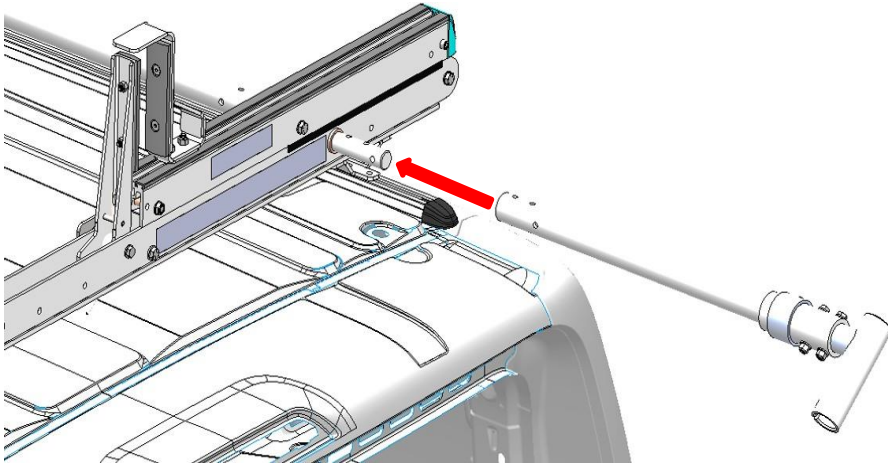

Step 15.
Install handle assembly into rear crossbow

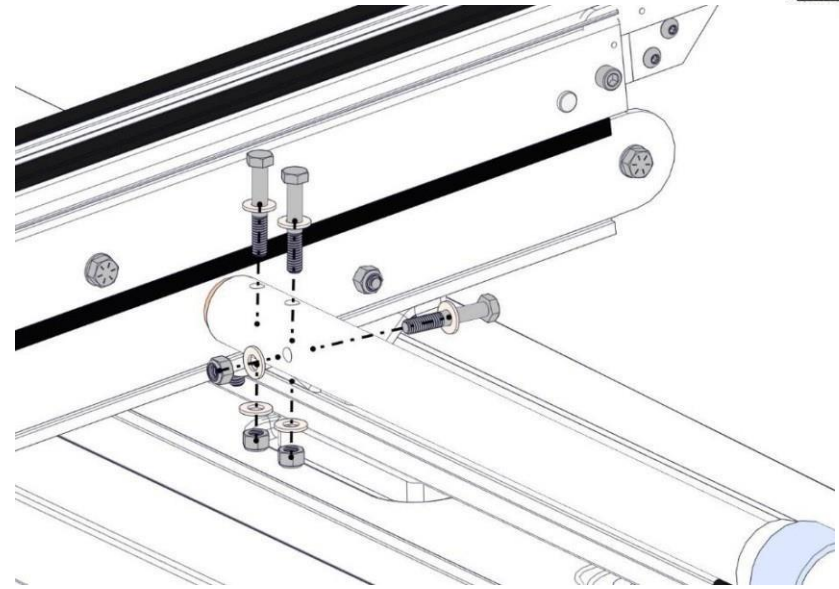

Step 16.
Fasten handle with 5/16 X 2-1/2 bolts (6) and washers (12) and apply seize to bolts

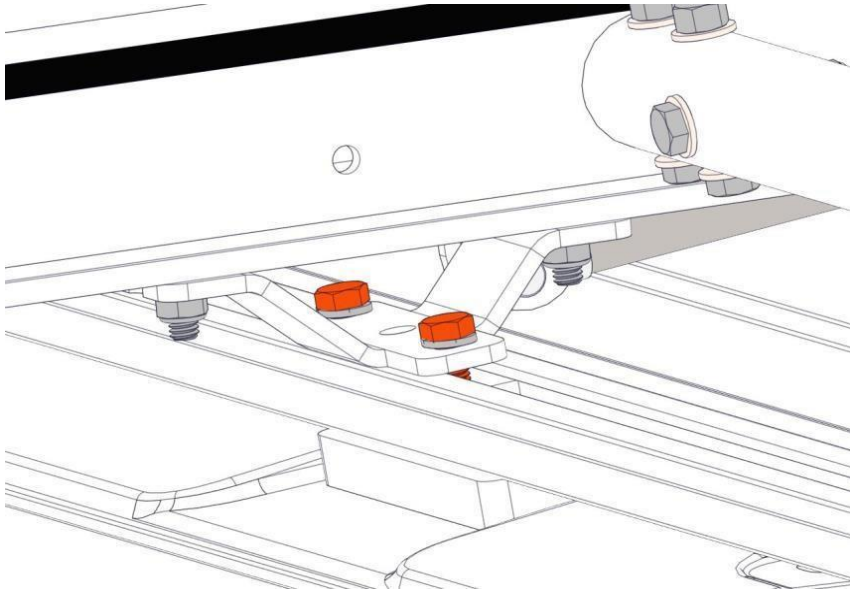

Step 17.
Tighten crossbow bolts.