

COMMERCIAL UTILITY PICKUP RACKS



Masterack® utility work tops for pick-ups are the professional's choice for tough jobs.

- > Pick-up utility tops are perfect for CATV, telecom, security, construction, or any business need. Add job specific storage systems shown on pages 50-51, or design your own.
- > Available as durable, lightweight aluminum tops and Workmaster™ heavy-duty steel work tops. Both feature fully welded frame construction.
- > Utility tops are available with a choice of side and rear door configurations.
- > Add a Utility Carrier, Masterack® Ladder Rack, or Slide-Down™ Ladder Rack to any utility work top. (Ladder rack reinforcement recommended)



Single Ladder Rack

As shown includes:
020991 Crossbow for Utility Tops
020245 Ladder Rack for Extension Ladders

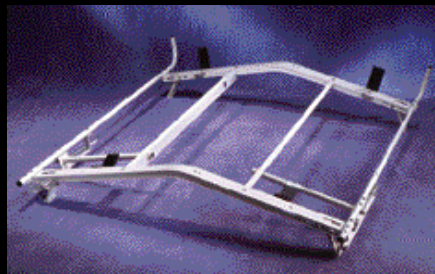

Single Ladder Rack

As shown includes:
020991 Crossbow for Utility Tops
020245 Ladder Rack for Extension Ladders
021226 Ladder Rack Step/Combination Ladders



Utility Ladder Rack

As shown includes:
020232 Utility Carrier for Work Tops

Heavy-Duty Pickup Racks

- > Rated for the maximum load allowed by the truck manufacturers.
- > Support legs mount to the bed floor and side rails for increased load capacity and stability.
- > Fits all Full Size pickups with 6ft. to 8ft. beds. Rack width between truss rails is greater than 48". Includes four crossbars.
- > The only pickup rack that is both zinc plated and powder coated for the maximum in outdoor protection. Low gloss black finish matches vehicle trim.



025355 HD Pickup Rack
48" H bed floor to truss rail
12' L split truss rails

VersaRack™

- > Adjustable to fit virtually all sizes and models of pickups.
- > Aluminum construction is rugged and reliable, never rusts.
- > VersaRack™ is lightweight (55 lbs.), yet strong (800 lbs. tested capacity).
- > Channel system design accepts a wide variety of accessories.
- > Installs in many trucks without drilling using the optional PocketLok™ system.
- > Fits all pickups with 5-1/2 ft. to 8 ft. beds, 48" wide between side rails.



Patented, universally adjustable corners are made with Kevlar™ glass fibers and nylon to make the rack strong and rigid. Self-indexing system provides positive positioning and reduces assembly time. Lightweight, can be lifted by one person.



027411 VersaRack™ Full Size Pickups
027400 VersaRack™ Mid-Size/Mini trucks



VersaRack™ Accessories

- 027419 Strobe Bracket
- 025085 12V Strobe Light
- 027423 Ladder Clamp
- 027412 Additional Square Crossbar
- 027413 Additional Round Crossbar
- 027414 Gelay™ Protective Cover Square
- 027415 Gelay™ Protective Cover Round
- 027420 Universal Tie-Downs (set of four)

PocketLok™ mounting System
(Specify make and model)

COMMERCIAL PICKUP INTERIOR PACKAGES

PICKUP PACKAGES

Pickup packages offer quick, easy access to tools and equipment. For use with commercial cab high plus 6" tops. Solid steel and welded wire interior systems available for pickups. Shelving fits bed sides to allow clear center aisle space. Order pre-packaged interior kits, or mix and match components to fit you own needs.



General Contractor Package				
> Pickups 6-8ft Bed				
PACKAGE #027646				
Item #	Description	Qty.	Page	
1	021417 Shelf, Open End 36"H x 37"W x 12"D	2	34	
2	021419 Shelf, Open End 36"H x 25"W x 12"D	2	34	
3	025527 Triple Hook Assembly	2	36	
4	027259 Three Drawer Parts Drawer 12"H x 18.5"W x 12"D	4	37	

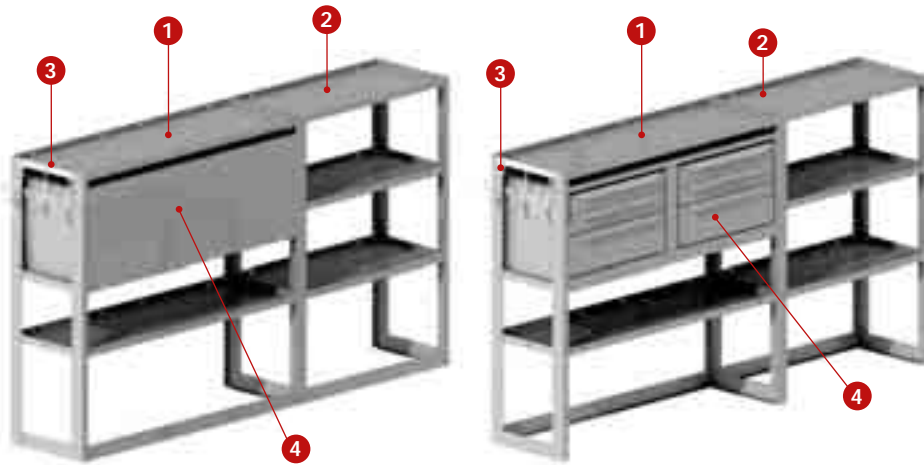

Commercial Repair Package				
> Pickups 8ft Bed				
PACKAGE #027647				
Item #	Description	Qty.	Page	
1	021007 Drawer Cabinet, 18 Drawer 11"H x 34"W x 12"D	1	37	
2	021389 Parts Tray 3"H x 37"W x 12"D	1	35	
3	021392 Storage Cabinet 24"H x 18.5"W x 12"D	1	37	
4	021417 Shelf, Open End 36"H x 37"W x 12"D	2	34	
5	021419 Shelf, Open End 36"H x 25"W x 12"D	2	34	
6	021471 Plastic Tote Bins 5"H x 8"W x 12"D	4	36	
7	022788 Two Drawer Parts Drawer 12"H x 18.5"W x 12"D	1	37	
8	025527 Triple Hook Assembly	1	36	

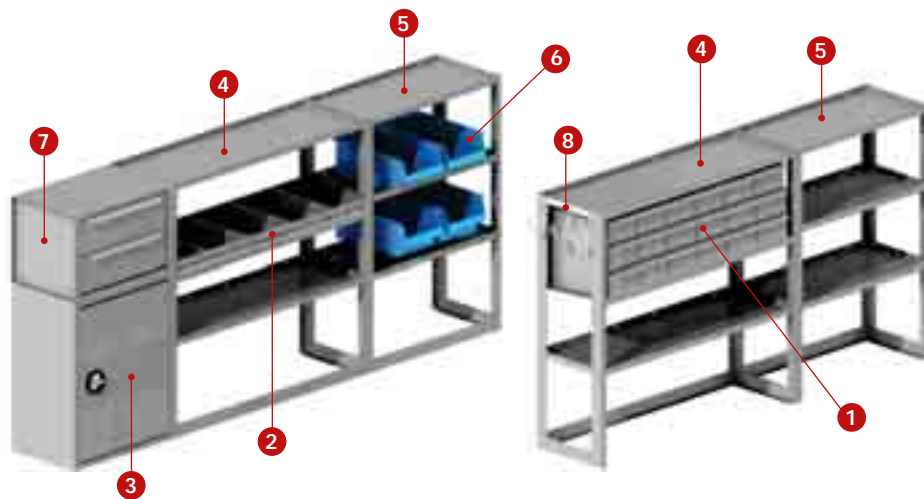

COMMERCIAL PICKUP INTERIOR PACKAGES

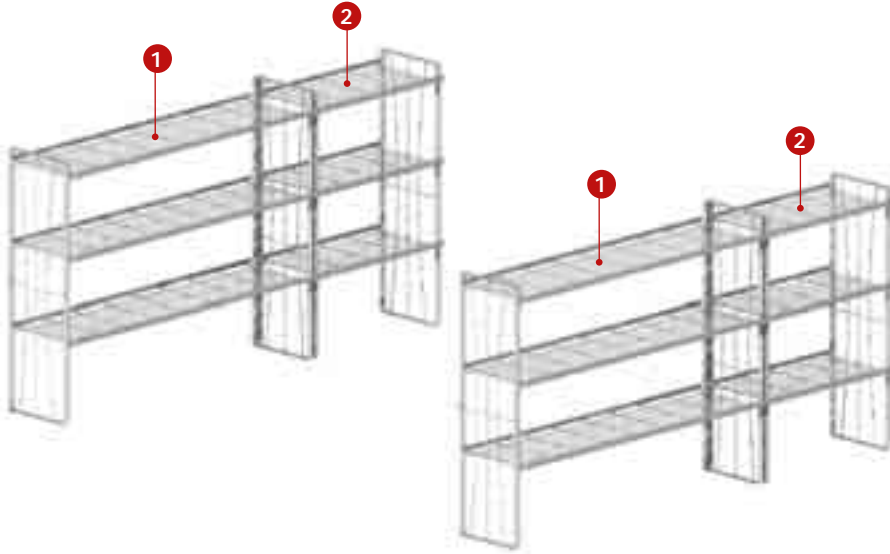

Utility Shelving Package

> Pickups 6.5-8ft Bed

PACKAGE #021580

Item #	Description	Qty.	Page
1 021551	Wire Shelf Module 39"H x 49"W x 12"D	2	44
2 021553	Wire Shelf Module 39"H x 25"W x 12"D	2	44

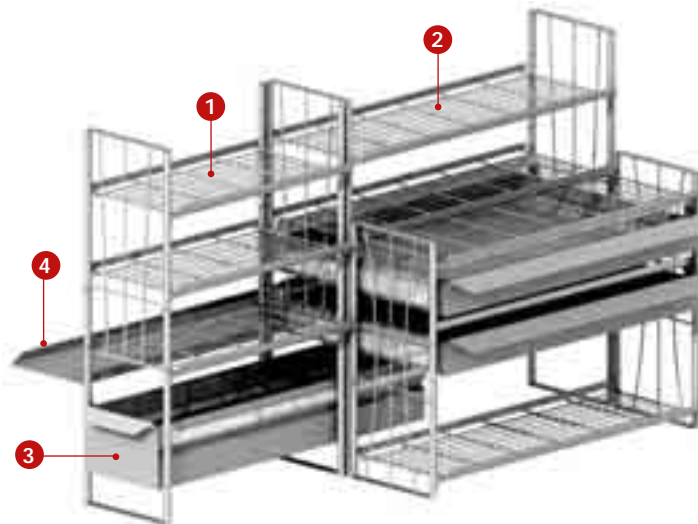

Telecom, Utility Construction Package

> Pickups 6-8ft Bed

PACKAGE #020936

Item #	Description	Qty.	Page
1 021553	Wire Shelf Module 39"H x 25"W x 12"D	1	44
2 022211	Step Down Drawer Module 39"H x 37"W x 24"D	1	45
3 025592	Drawer, Rear Pull Out 6"H x 37"W x 10"D	1	45
4 027501	Step Ladder Slide	1	39



PICKUP INTERIOR ORDERING GUIDE

For use with commercial cab high plus 6" tops. Lift-up, or sliding side doors required for interior side access.

Fit full size and compact pickups with bed length indicated.

Installation requires removal of bed liners.

Most van accessories (pages 34-39) will fit pickup interior systems.

Cargo mat and tailgate protector are available, please specify make, model, and bed length.

Determine proper vehicle payload capacity when planning commercial pickup systems.